

KM

Automated Entrance Systems

KM Systems, Inc.

4910 Starcrest Dr.

PO Box 3099

Monroe NC 28111

PH. 1-800-438-1937

1100 SERIES SLIDING DOOR

INSTALLATION INSTRUCTIONS
AND TROUBLESHOOTING GUIDE

SERIES 1100 ULTRA-GLIDE SLIDER (WITH ZII CONTROL)

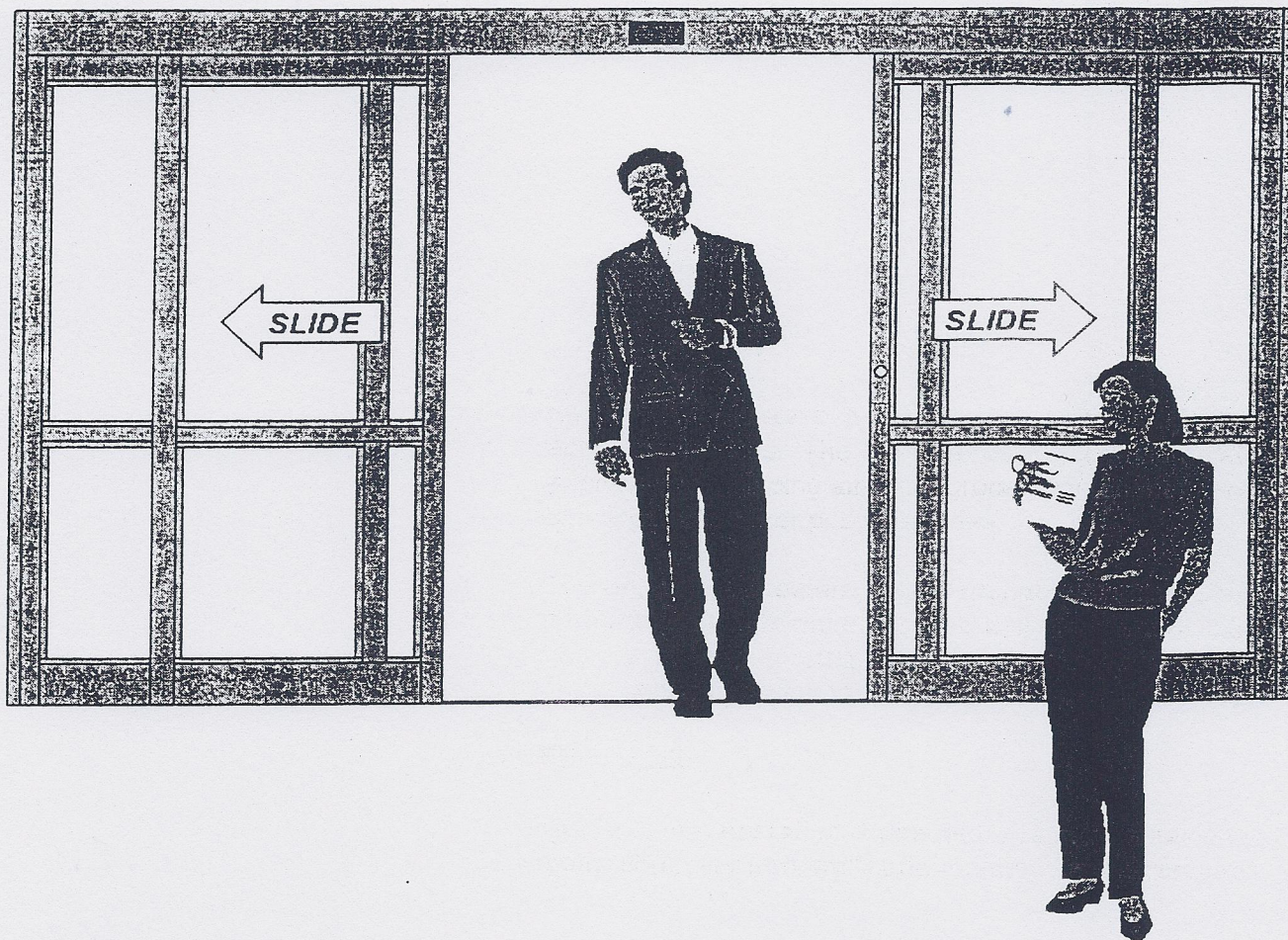

The KM Systems 1100 slider has been carefully designed, built, and tested to provide years of service.

The life of the door package is directly related to how carefully the installation is accomplished and how accurately the instructions are followed. Installation of this door package should be done by properly trained and knowledgeable installers with a working knowledge of local code requirements and the requirements of ANSI A156.10 Standards for Power Operated Pedestrian Doors.

Once the installation has been completed the door must be adjusted to any recommendations in this manual and all applicable codes and standards.

After installation and adjustment, the installer must instruct the owner in the safe use of the door, and provide the owner with the owners manual and explain the daily safety check list it contains.

SYSTEM DESCRIPTION

The KM Systems Series 1100 Ultra-Glide Automatic Sliding Entranceways are high-performance microprocessor controlled automatic sliding doors for pedestrian use. The package includes door frames, sliding door and sidelite panels, header with operating mechanism, service access cover, door carriers and all related hardware. The package does not include glass, glazing, or activation devices. The units are designed to automate entrances for applications including airports, grocery stores, home centers, hospitals, office buildings, and other public facilities.

The Series 1100 feature a drive train that consists of a brushless, molded DC motor and nylon reinforced timing belt. Movement is transmitted to the sliding doors by the belt through coordination with an idler pulley, and the sliding doors are suspended on four sealed ball bearing rollers.

FEATURES

The KM 1100 operation is directed by a self-contained microprocessor based motor controller ("control") offering the following features:

- Intricate adjustment of opening and closing speeds
- Intricate adjustment of braking (opening check) and cushioning (closing check) speed and position.

- Automatic recycle if an object is obstructing the opening or closing paths of the door. The control also offers a search feature which causes the door to reverse direction to the full open or close position if an obstruction is met, and then close/open the door at slow speed to search for the obstruction. If the obstruction is again encountered, the door is shut down and an alarm is triggered. If the obstruction is not encountered the door completes its cycle and returns to normal operating speed on the next activation signal.
- Adjustable hold open time from 1-30 seconds.
- Adjustable reduced door opening size for heating/cooling conservation
- A self-monitoring system which adjusts speeds, recycle force, and other operating characteristics on every open/close cycle for changes in temperature, wind load, pressure, and mechanical drag.

All drive and control components are enclosed in a 4-1/2" by 6-1/2" aluminum extruded header. The header includes a channel in which the idler pulley, motor/gearbox, control, power transformer, and terminal blocks are mounted. The door carrier glides on a extruded aluminum track fastened to the header.

To provide quiet operation, a nylatron® track cap is applied to the track and acts as barrier between the rollers and the track. An extruded close-out shelf provides a barrier to any unauthorized exploration into the header from the door opening area. A service access cover hinges on the header and snaps into the close-out shelf to form a completely contained header mechanism.

A 120/100/24 VAC transformer is used to supply 100 volts to the control and 24 volts to the activation and safety devices. The 100 and 24 volt secondary are isolated. The 24 volt supply is protected by a 2 amp fuse, and a resettable circuit breaker is used to protect the 100 volt circuit and provide a disconnect means for servicing control, and/or motor/gearbox.

NOTE: GLASS AND GLAZING ARE NOT INCLUDED IN THE PACKAGE. THE GLAZING MATERIALS IN BOTH THE DOORS AND SIDELITES SHALL COMPLY WITH THE REQUIREMENTS IN THE AMERICAN NATIONAL STANDARD PERFORMANCE SPECIFICATION AND METHODS OF TEST FOR SAFETY GLAZING MATERIALS USED IN BUILDINGS, Z97.1-1975.

OWNER INFORMATION TO BE PROVIDED BY THE DISTRIBUTOR / INSTALLER

- Location and proper use of the power switches.
- Location of the main cutoff breaker.
- Necessary warnings not covered in general instructions.
- Owners Manual and Daily Safety Checklist.
- Phone number(s) for the local servicing dealer.
- What to do in the event that a dangerous situation should occur, and how to shut the doors down and call for service.

TABLE OF CONTENTS

PRODUCT INVENTORY / PREPARATION	4
FRAME AND TRANSOM ASSEMBLY	5
DOOR FRAME INSTALLATION.....	6
THRESHOLD AND BOTTOM GUIDE INSTALLATION.....	7
SIDELITE INSTALLATION	8
SLIDING DOOR INSTALLATION.....	9
SLIDING DOOR PRELOAD ADJUSTMENT	10
SLIDING DOOR SPRING RETURN ADJUSTMENT	10
CONTROL OPERATION and ADJUSTMENT	11-14
TROUBLESHOOTING GUIDE	15-17
ELECTRIC LOCK	18
WIRING DIAGRAM.....	

TOOL LIST

- Knife
- 4' or 6' ladder
- Wire cutter
- 4' level
- Hammer
- Tape measure
- Chalk line
- Combination wrench set (1/4" to 7/8")
- Screwdrivers (#2 Phillips, Sm. & Med.)
- Electrical tape
- Extension cord
- 3/8" cordless drill
- Hammer drill
- drill bit set to 3/8" & 1/4", 5/16 masonry bits
- Hex wrench set
- Channel lock pliers
- slip joint pliers
- Flat and rat tail files
- Vise grip pliers
- Shim material (shingles)
- caulking and gun
- ratchet wrench set (1/4" to 7/8")
- Multimeter
- wire ties

PRODUCT INVENTORY AND PREPARATION

There are several different type packages built. Make sure the package you are installing meets the needs of the opening intended. (Inside slide, outside slide, or surface mount)

1. Once the material has been received inspect all cartons for completeness of order. There should be at least six cartons for a standard bi-part package. The following items should be present.
 - A. Header Assembly (contains sensors and parts bag)
 - B. Side Jambs (contains side jambs and transom)
 - C. Door panels (contains vinyl)
2. Check the door opening for plumb and level. The floor must be checked for any high spots. The header can be used for the straight edge to detect any variation in the floor surface. Fill the low areas to make the floor level. See the **figure 1** below for additional information.

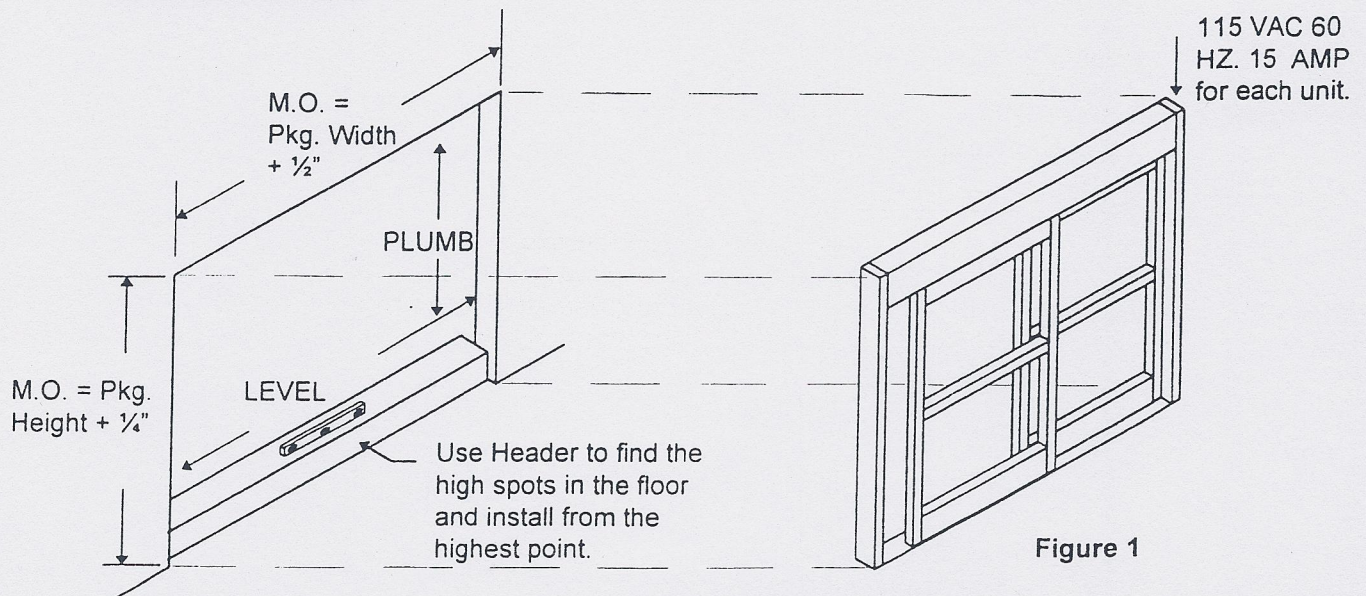

- Do not allow over 8' of unsupported header. (The fixed panel is considered as suitable support for the header.) If the unit is equipped with a transom, and the unit length is greater than 8', the frame must support the weight of the transom, glass, and an additional 130 lbs. for unit lengths up to 12', and 260 lbs. for units up to 16'. Lay out the frame components and transom (if equipped) on the floor along side the door opening. Be careful not to scratch the finish. Position the header so as to allow for lifting into the opening once all the components have been assembled.

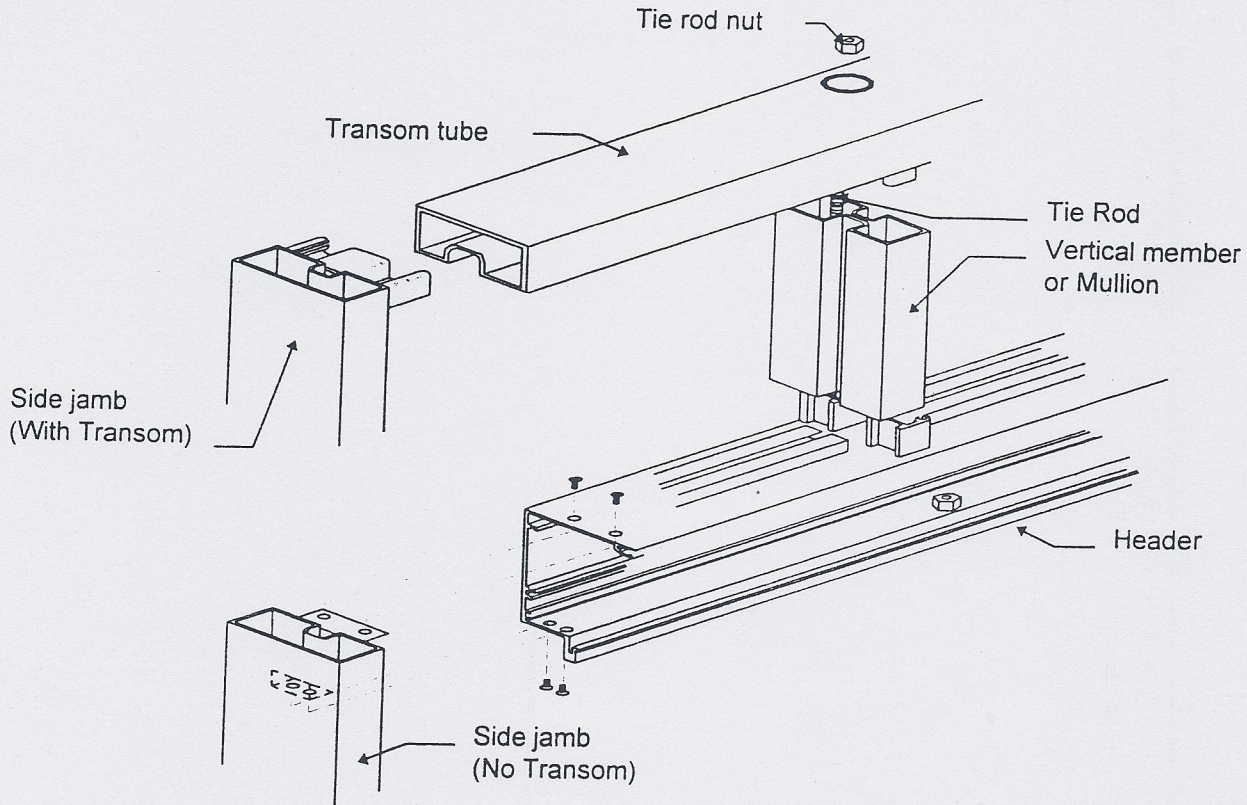
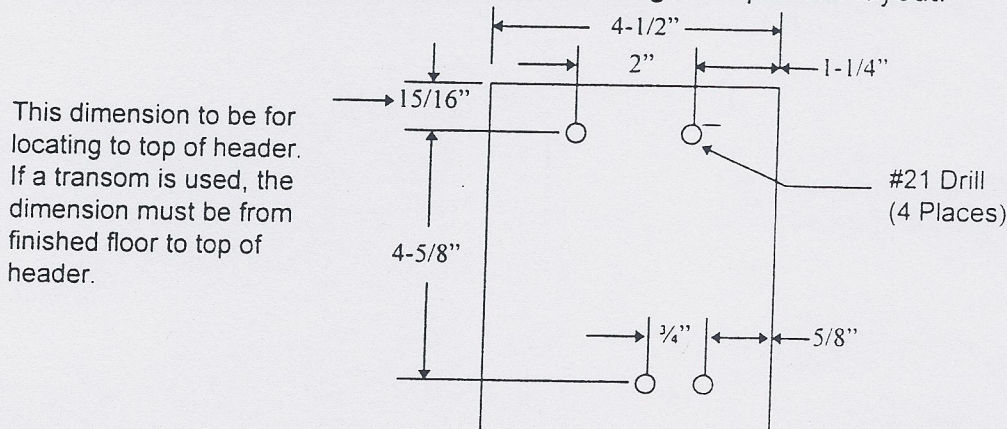

Figure 2

When using jambs by others, use the following hole pattern layout.



This dimension to be for locating to top of header. If a transom is used, the dimension must be from finished floor to top of header.

Figure 3

Once the door frame has been assembled, place the frame in front of the opening on the floor so that the bottom of the jambs are at the base of the opening as shown in Figure 4 below. Snap a chalk line across the opening where the jamb line is going to be.

Before lifting the frame into place, check to make sure the cover side of the header will end up on the correct side of the opening. If the unit has sidelites that breakout, the cover will be interior; if the sidelites are fixed or the unit is surface mounted, the cover will be exterior.

Lift door frame into the opening and set the frame plumb and square to the highest spot on the floor and position the frame within the 4-1/2" dimension as needed. If the high spot or swell in the floor forces the frame to go higher than the rough opening will allow, **Do Not** install the frame. Door height adjustment will be reduced if the frame is installed with this condition present.

THIS IS NOT ACCEPTABLE. Have the contractor rework the floor so the doors can be properly installed.

If there is room to raise the frame up even with the high spot in the floor, shim the bottom of the jambs to the high spot.

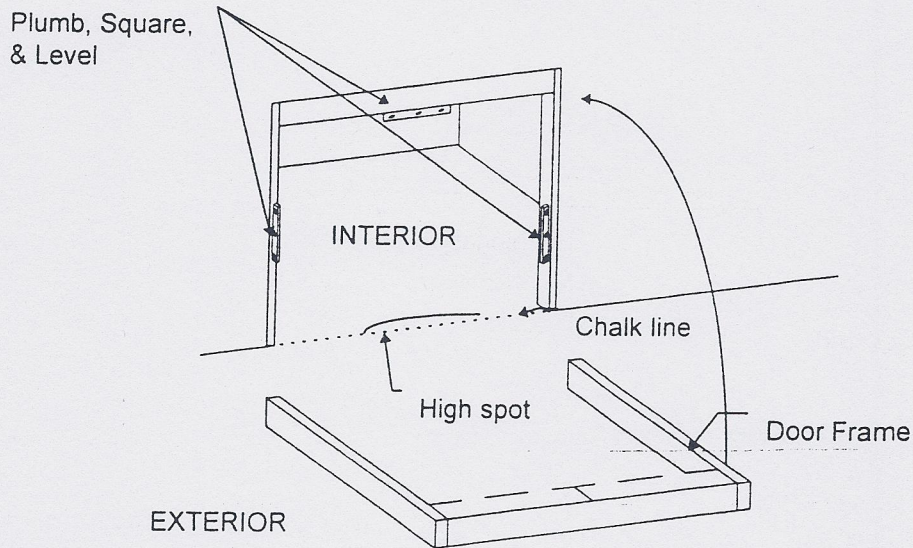

Figure 4

Using wood shims, plumb and square the header and jambs in the opening. Fasten the door frame to the opening with the appropriate type and number of fasteners for the size of the door package being installed. Fasten the header to the overhead every 36" or less.

Snap a chalk line between the jambs on the interior 1-3/4" face of the jambs. This line will be used to locate and to install the bottom guide system.

The bottom guides must be installed level and in line with the frame for the door package to properly function. If the high spots referred to on page 6 were not corrected as indicated, proper location of the bottom guides will be extremely difficult. Correct high spots and continue.

Identify the type of guide system being used with the door package. The standard guide for a fixed panel unit (o-sx-sx-o) is a sway rail with or without threshold; for full breakout units (so-sx-sx-so), the standard bottom guide is a pin guide which is the same with or without threshold. (See Fig. 5 below)

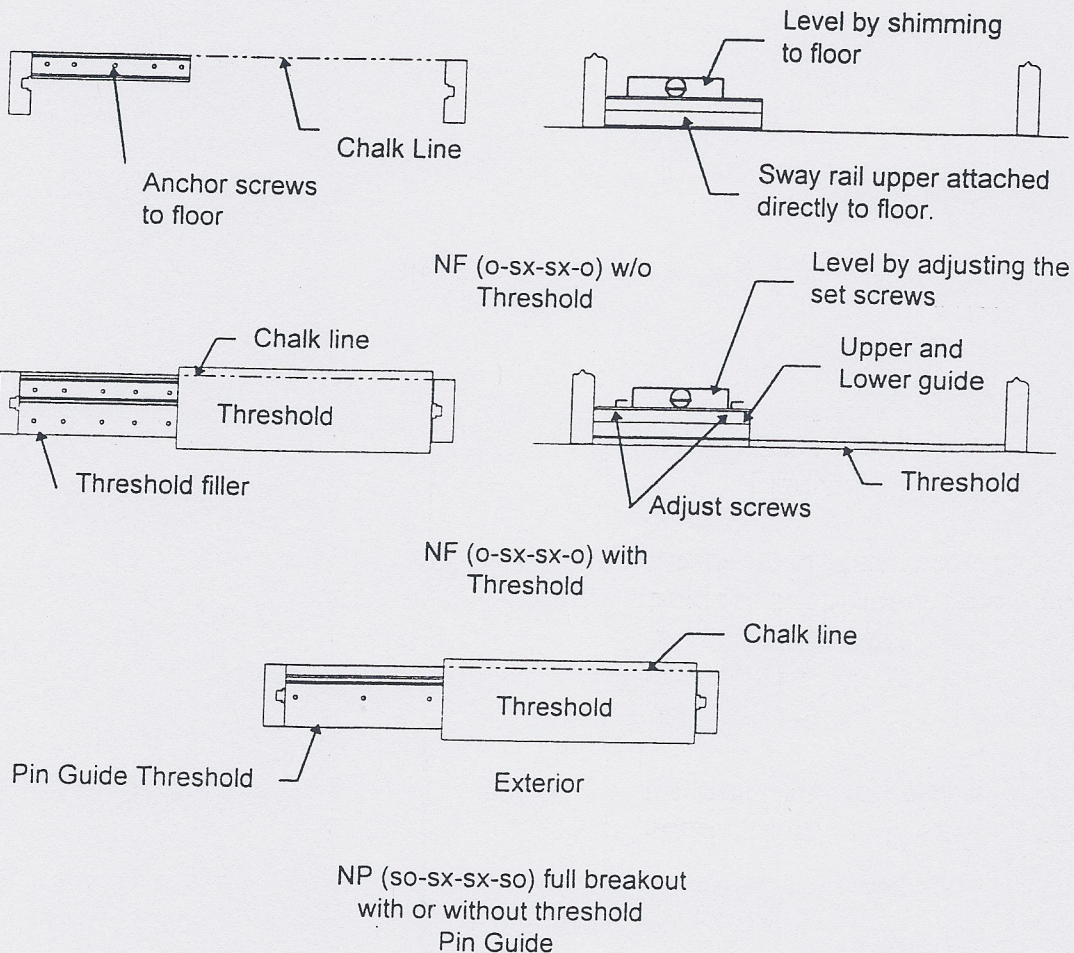

Figure 5.

Caution: If the door frame is not plumb, square, and level, do not secure the threshold to the floor. Recheck the frame, install the doors; then secure the threshold.

SIDELITE INSTALLATION

There are two types of sidelites. The first type is the full breakout sidelite that has a jamb or floor mounted bottom pivot. To install, place the sidelite on the bottom pivot first and rock the sidelite into the upright position and drop the top clevis pin into the top pivot block. Carefully route the safety beam wires through the hole next to the pivot location and secure along the top rail of the sidelite. (See figure 6 below)

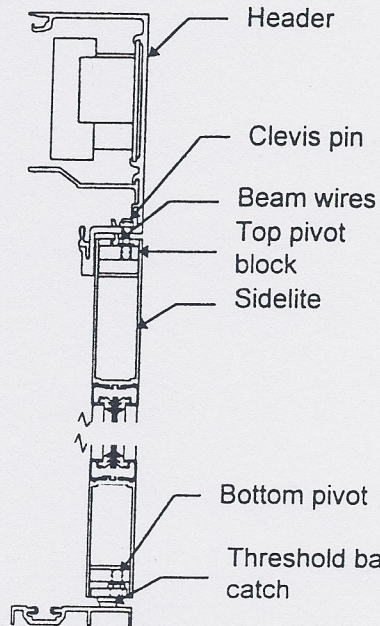

Figure 6

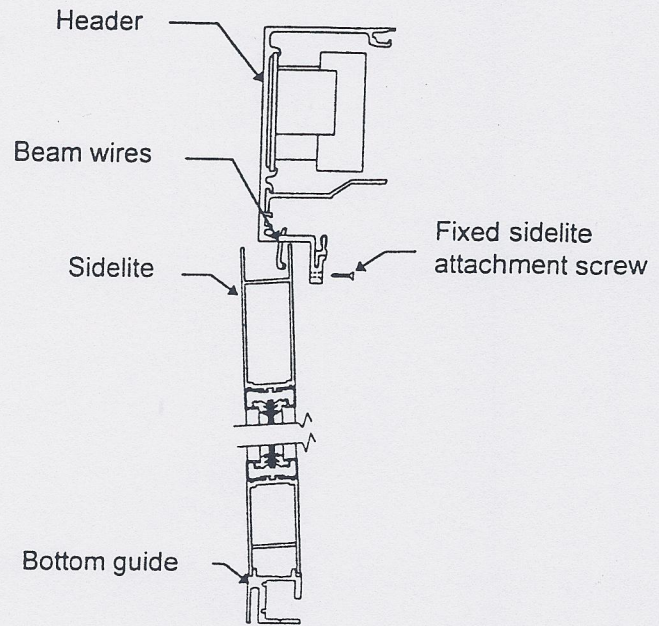

Figure 7

To install the fixed sidelite to the header, make sure the bottom guide is set properly to the floor. Install the sidelite to the top of the guide. Secure the sidelite to the header with the screws shown in figure 7. Additional screws can be placed through the stile and into the jamb before the sidelite is glazed.

For units ordered with floor mounted bottom pivots, secure the bottom pivot to the floor as shown in figure 8 below.

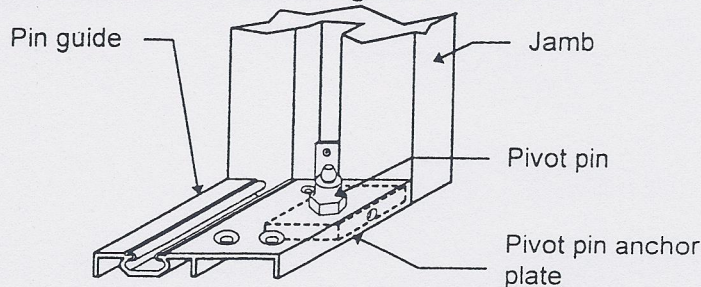
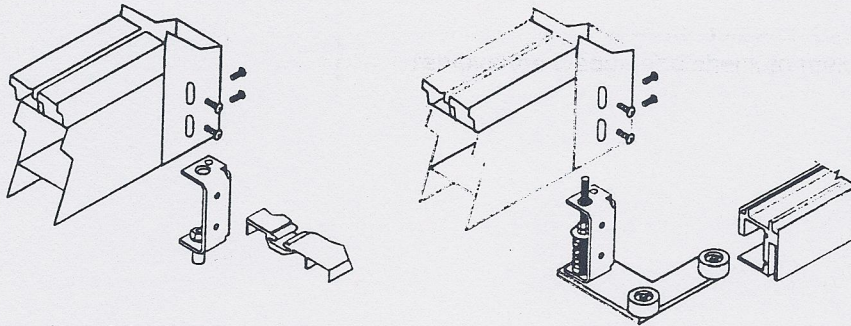

Figure 8

SLIDING DOOR INSTALLATION

Position the door so that it will panic to the exterior of the building when broken out.

Install the door portion of the bottom guide in the pivot stile of the door using four 10-32 screws provided.



Position the door portion of the bottom guide into the guide rail or the pin guide track (depending on the type bottom guide used).

Place the door so that the slots in the upper catch rail are lined up with the 5/16" tapped holes in the door carrier brackets. Thread the two 5/16"-18 x 1-1/4" hardened hex head hanger bolts with the flat washer and split washer through the slots into the door carriers. Tighten the hanger bolts until the door does not sag, but do not tighten all the way.

Adjust the door height (floor clearance) by threading 1/4"-20 hex head bolts above the slots in the catch rail to put pressure on the 5/16" hanger bolts and the height adjustment screws to lock down the door height position. Once proper height has been adjusted make sure there are not any gaps between the doors or door and jamb from top to bottom. It may be necessary to readjust height adjustment screws.

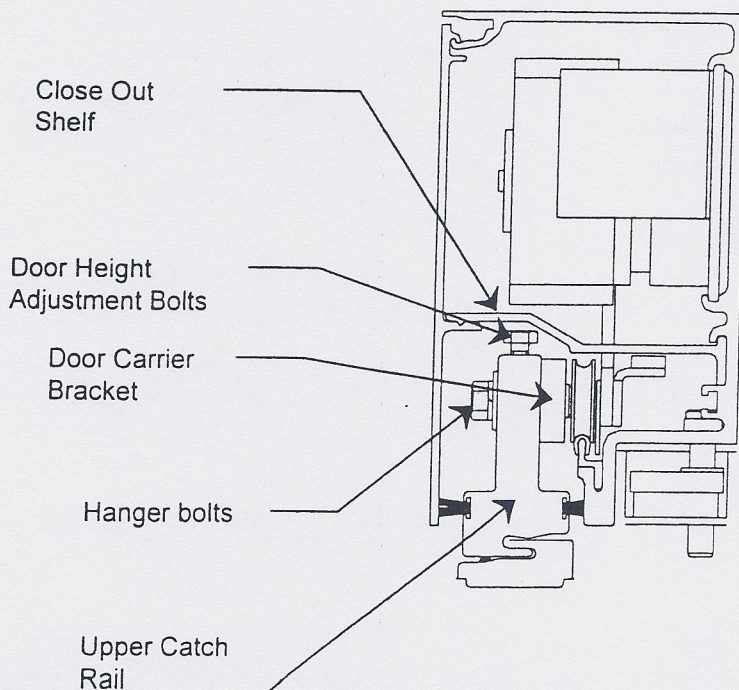

ADJUSTING THE SLIDING DOOR PRELOAD

Loosen the two (2) carrier pivot arm 1/4"-20 hex bolts which lock the carrier pivot arm assembly to the upper catch rail.

Break out the door just enough to get to the preload adjusting set screw. Place a wedge under the leading edge of the door to relieve the force on the set screw; turn the screw clockwise until resistance is detected and remove the wedge and check to make sure the door does not drop down. Repeat this process if the door drops down and then tighten the carrier pivot arm 1/4"-20 hex bolts.

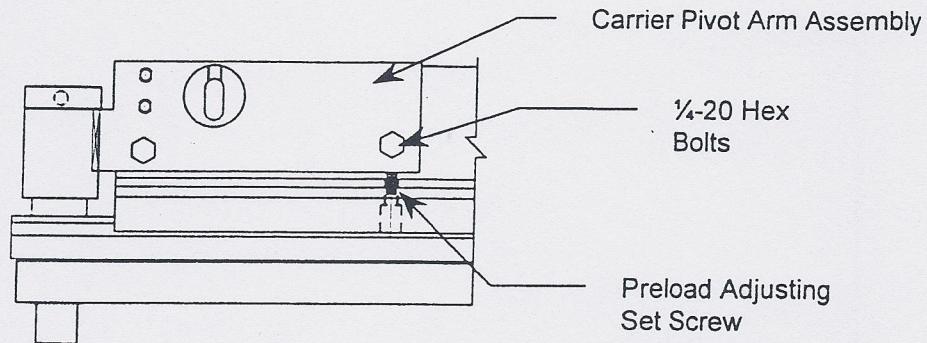

ADJUST THE SLIDING DOOR SPRING RETURN

The torque generated by the spring concealed in the pivot stile of the sliding door on units with spring close doors can be adjusted without taking the doors down.

- Referring to the drawing below, loosen screw #1 and remove screw #2.
- With an 11/16" wrench on the torque adjusting nut (3), relieve the tension against the lock dog (4).
- Raise the lock dog (4) to clear the top of the square torque block (5).
- Turn the adjusting block 1/4 turn towards the door closed position and drop the lock dog down to prevent the torque block from turning while maintaining pressure on the wrench.
- Repeat the above steps until the torque is strong enough to bring the door to the closed but not latched position.

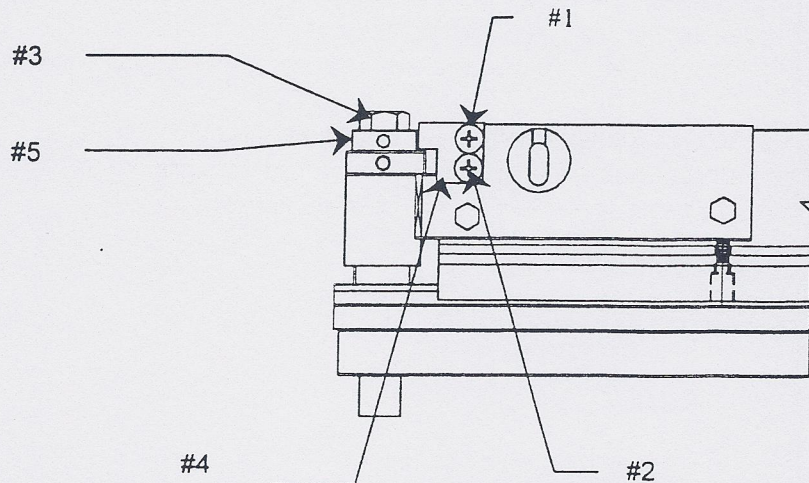

Operation

The KM systems 1100 slider does not use conventional limit switches to determine door position. Door position is determined when the control counts the pulses generated by the encoder in the motor gearbox as the door moves through its learn cycle. The learn cycle consists of a close and open or teaching stroke.

Power Up

Once the power is applied to the slider the control sends the door to the closed position unless there is an activation signal. If there is an activation signal present, the door will go open in slow mode and remain there until the signal is removed. During the time the door is going open slow, the control counts the pulses so it can return the door to the closed position at a more normal rate of speed. Once the door is allowed to get to the door closed position and shut down, the control will recognize this as the door closed position. The next activation is the **Teaching Stroke**.

Teaching Stroke

The teaching stroke should be set to approximately 70% of the full door stroke (clear door opening), allowing the control adequate time to brake the door to low speed and move gently to the full open door stop.

The length of the teaching stroke is set using the "T.STR" rotary switch on the control. The numbers represent door stroke size; (See table below) the larger the number, the greater the door stroke. When the setting is "0" the door will go open in slow mode only. Setting "1" through "3" are the most commonly used settings for typical slider applications, and the factory will set all new sliders to the proper setting for the door size ordered. (Note: Power must be removed from the control and then reapplied after the setting has been changed for the new setting to take effect.)

Once the teaching stroke has been set, activate the door with either the sensor input or the test button. The door should go open to about 70% of full door stroke and brake to cushion speed. If the door slams into the open stop, the setting is too high and must be changed to next smaller number and tested again. If the door brakes too soon, the number needs to be increased to allow the door to get farther open. (Remember to remove and reapply power)

This completes the door stroke teaching process. The door stroke is stored in memory, and anytime the power is removed from the control the memory is cleared. Therefore a new teaching cycle is initiated whenever the 120V power is reapplied.

Caution: Although the control will self correct in three complete cycles, **DO NOT** leave the teaching stroke set to a number that will allow it to slam open. Door slam will eventually cause damage to the mechanical drive components in the header causing premature failure of the sliding door package.

	0	1	2	3	4	5	6	7	8	9	A	B	C	D	E	F
OPENING TIMER (SEC.)	LH								RH - BI-PART							
	1	2	3	5	7	10	20	30	1	2	3	5	7	10	20	30
T.STR (in.)	Slow	12	24	36	48	60	72	84	118	158						
HALF OPEN (%)	Auto								Constant							
	25	38	50	75	25	38	50	75								

Alarm ON/OFF

The control is equipped with an audible alarm in the event there is a problem with the operation of the door system. The slide switch allows for removal of the audible part of the alarm. The power LED will still flash the coded alarm message in the event there is an error. (Refer to troubleshooting section for explanation of coded error messages.)

Close Speed (Clos.sp.) See Table

Closing speed adjustment is accomplished by setting the rotary switch from "0" to "9" with "0" being the slowest speed and "9" being the fastest. **Caution: Do not adjust the closing speed faster than one foot per second on sliders used for public access.**

Cushion

Cushion is the door speed after the door has slowed down and is traveling the last several inches of either the door open or close cycle. The rotary switch has settings from "0" to "9" with "0" being slow and "9" being fast.

Open Speed (Open.sp.) See Table

Open speed adjustment is accomplished in the same manner as close and cushion speeds are.

Teaching Stroke (T.STR) See Table

Teaching stroke is defined on page 11 and will be set by the factory for typical door applications.

Braking Force See Table

The braking force can be selected in either the "Auto" mode (0 to 3) or the "Fixed" mode (4 to 7) depending on the type of application. In the "Auto" mode, the computer controls the braking action of the door depending on the setting of switch S1. In the fixed mode the computer brakes the door at predetermined intervals regardless of the setting of S1. This will be factory set and should not require adjustment in the field on new installations. **Do not use positions 8 and 9**

Switch S-1

This switch selects the braking point/gearbox type being used whether it is the standard (18ZII-switch down) or the heavy duty (30ZII-switch up).

Switch S-2

This switch selects the open press function, which applies a low voltage to keep a small open pressure on the door in the open direction. Always factory set to the upper or on position.

	0	1	2	3	4	5	6	7	8	9	A	B	C	D	E	F
OPENING TIMER (SEC.)	LH								RH - BI-PART							
	1	2	3	5	7	10	20	30	1	2	3	5	7	10	20	30
T.STR (in)	Slow	12	24	36	48	60	72	84	118	158						
HALF OPEN (%)	Auto				Constant											
	25	38	50	75	25	38	50	75								

Braking Force	
Auto	Fixed
0 ▲ 3	4 ▲ 7

Half Open (HO-%) See Table .

The half open function is initiated when the toggle switch for half open is turned on. This switch is not supplied unless ordered.

The rotary switch has two modes to select from, the automatic mode or the manual. In the automatic mode the door will go to the secondary door opening width selected (25%, 38%, 50%, and 75% of full open-position 1 through 5 respectively) and if the activation lasts longer than 15 seconds the control will send the door to the full open position. In addition the control will also send the door to the full open position if three cycles occur without the door getting closed and shutting off.

In the manual mode the rotary switch has the same four percentage settings (4 through 7), but the door will always go to the secondary opening and stay there until the time delay is satisfied and will never go to the full door open position. **Do not use positions 8 and 9**

Torque Adjustment (Torque) See Table

Some applications require the control to apply more power to the door because of size or outside influence. The rotary switch for torque has four settings for the close cycle (0 through 3), and four settings for the open/close cycle. This adjustment will be set at the factory but may need to be altered depending on individual applications. **Do not use positions 8 and 9**

Open Timer See Table

The hand and time delay of the slider are accomplished by adjusting the open timer rotary switch. Positions 0 through 7 are for a left hand slide unit, and the time delay increments are fixed at 1,2,3,5,7,10,20,and 30 seconds respectively. For right hand and bi-part sliders, the switch positions are 8 through F with the same time delays as shown for a left hand.

Sensor LED (RED)

This LED serves two functions. The first function is when activation from approach sensors occurs. The second function is when the safety beams are activated.

Power Supply LED (GREEN)

This LED also serves two functions. The first function is illumination when power is applied to the control. It also serves as the error LED and will flash the coded error sequence as described in the troubleshooting section of this manual.

	0	1	2	3	4	5	6	7	8	9	A	B	C	D	E	F
OPENING TIMER (SEC.)	LH								RH - BI-PART							
	1	2	3	5	7	10	20	30	1	2	3	5	7	10	20	30
T.STR (in.)	Slow	12	24	36	48	60	72	84	118	158						
HALF OPEN (%)	Auto				Constant											
	25	38	50	75	25	38	50	75								

Torque Adjustment	
Close	Open/Close
0 ▲ 3	4 ▲ 7

Switch SZ-1 See Table Below

Sliders that are supplied with battery backup can be set up to either open the door or close the door upon power failure. When SZ-1 is selected to the upper position, the door will go to the open position when power is removed. The lower position closes the door.

Switch SZ-2 See Table Below
 Lower position only (sliding)

Switch SZ-3 See Table Below

Input signal logic is provided for easy adaptability. When sz-3 is in the upper position the control will open the door when the circuit goes from a normally closed signal to a normally open signal. In the lower position the circuit goes from normally open to a closed circuit. Factory setting is the lower or normally open logic.

Switch SZ-4 & 5
 Not applicable to product.

Switch SZ-6 See Table Below

Sliders that are supplied with electric lock systems will have this switch set in the lower position to tell the computer that the lock is on board.

Switch SZ-7 See Table Below

The control will accept two different methods of activation logic. "One contact activation" (upper) is time delay type where the time can be set and the door will time out and close. "Ratchet" activation requires a contact activation to open the door and another contact activation to close the door. If the second activation does not occur, the door will stay open indefinitely. In Order to use the "Ratchet" function it is necessary to connect the activation device to the plug that has the (RS) connection. This plug is located next to the activation plug and will require a special different harness. (Call for to order)

Switch SZ-8 See Table Below
 Lower position only (normal activation)

Test Button

The Test Button is used as an activation device for use when setting up the control or troubleshooting.

	S-1	2	SZ-1	2	3	4	5	6	7	8
Upper	Braking Point 30zII	Press Open	B.O.	—	Input Signal N.C.	—	—	E. Lock NO	One Contact Button	—
Lower	18ZII	Off	B.C.	Sliding	N.O.	—	—	YES	Ratchet	Normal Activation

Error Coded Alarms

The control incorporates seven audible alarm sequences that can be initiated when different malfunctions occur. Either the beeper in the control or the power LED flashing on and off identifies these alarms. The Beep or flash will either be shorts (•) or longs (-), and the sequence will identify the problem. The following is an explanation of these beep sequences.

- 1. **No Door Operation; No Programming**
 Check to insure incoming power is supplied.
 The door may have been turned on before
 Being unlocked causing the circuit breaker
 To trip.

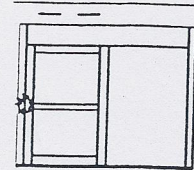

- 2. **Safety Stop on Obstruction**
 If the door encounters an obstruction on
 the opening stroke, the control stops the
 door and sounds an alarm. (Safety stop)

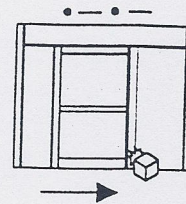

- 3. **Recycle on Obstruction**
 If the door encounters an obstruction on the
 closing stroke, the control safety reverses the
 door and re-closes it at a low speed searching
 for the obstruction. If the obstruction has
 been removed, the door closes at low speed
 and then resumes normal operation. If the
 obstruction has not been removed, the control
 shuts the door down and sounds the alarm.

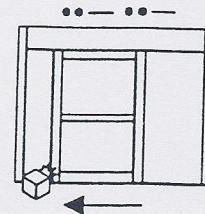

- 4. **Loose Belt**
 If the belt tension is not set properly, the
 control will detect excessive pulley rotation
 and the door will be erratic. The alarm will
 sound and will continue to sound at intervals
 until the tension is fixed.

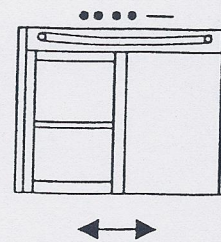

- 5. **Broken Belt**
 If the timing belt breaks, the motor will
 continue to run for approximately three
 minutes, and then an alarm will sound.

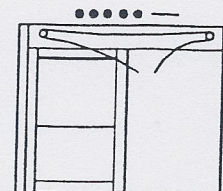

6. Overload

If the control encounters excessive friction or mechanical forces, the motor will turn slowly trying to overcome the friction then an alarm will sound.

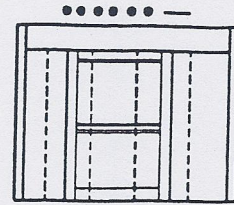

7. Internal Control Problem

The control has a built-in diagnostic feature which checks for proper control operation continuously. If an internal problem is detected, the unit is shut down and an alarm will sound.

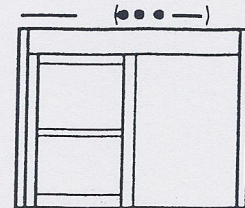

ADDITIONAL TROUBLESHOOTING AIDS

PROBLEM	POSSIBLE SOLUTION
Door will not open	<ul style="list-style-type: none"> •Check to make sure the power is applied to the control and the sensors. •Check sensing/ activation devices and wiring •Confirm proper operation of sensors by watching LED in control. •Try test button –if the test button works, the problem is in the sensors or wiring.
Door will not close	<ul style="list-style-type: none"> •Check to see if either or both of the LED's are on for the sensors or safety beams. •If the "SENSOR" LED is on, check to see if the sensors are working properly; if so, check wires. •If the safety beam LED is on, check to see if any damage has occurred to the individual emitters and detectors. Check to make sure the beam module has power applied. Beams are fail safe so when power is removed the door will stay open after it is activated.
Door opens or closes only six inches or so and shuts off.	<ul style="list-style-type: none"> •Panic circuit is shorted and the control thinks the door is panicked out. Check magnets in the sidelite.
Door slams open each time the power is turned on.	<ul style="list-style-type: none"> •The teaching stroke setting is set on a number that is set too high for the size door. Change the setting to next lower number and turn off the door and back on.—Retry (see page 11)
Door rocks back and forth when activated	<ul style="list-style-type: none"> •Bottom guide system binding •Door rubbing on sidelite or frame.
Door "GHOSTS" or recycles open and close.	<ul style="list-style-type: none"> •Check activation devices •Check safety beams •Check for door binding. •Check surroundings for movement in the pattern area of the door.

Troubleshooting Aids continued

PROBLEM	POSSIBLE SOLUTION
Door vibrates in the closed position when activated but will not move.	<ul style="list-style-type: none"> •This problem occurs with units that have electric locks installed in them. •Check the microswitch that is on the electric lock mechanism. As the plunger comes up, it must activate the lever on the limit switch before the computer will let the door move. (Door just vibrates) •Check for the plunger relaxing down slightly and coming off the lever.
Door drops down when panicked out	<ul style="list-style-type: none"> •Readjust the door preload at the pivot arm assembly. (see page 10 for adjustments)
Door does not spring back to the closed position (but not latched) on fixed panel (O-SX).	<ul style="list-style-type: none"> •Improper spring load adjustment. See page 10 for spring adjustment procedures.
When door is activated it does not time out and close.	<ul style="list-style-type: none"> •Check sensors and beams.
Door goes into latch and backcheck too hard.	<ul style="list-style-type: none"> •Readjust breaking force for smooth operation.
Door closes when activated	<ul style="list-style-type: none"> •Check to make sure opening timer is set in correct section for the hand of slider installed •Check to make sure the SZ-7 switch is not in the down or ratchet mode. •Check the SZ-3 switch is in the correct logic for the activation system being used. (Typically N.O. logic)
Door runs too fast and will not slow down in latch and backcheck.	<ul style="list-style-type: none"> •Torque adjustment too high •Door speeds too fast. •Cushion speed too fast. •Switch S-1 set for 30ZII and not 18ZII gearbox. •Braking force too low.
Door vibrates excessively in the open position.	<ul style="list-style-type: none"> •Check belt tension.

Belt Tension

To tighten the belt, loosen the set screws in the idler pulley bracket and place a straight blade screwdriver in the small slot of the tension plate and twist the screwdriver.

Repeat as necessary until the belt is snug but over tight.

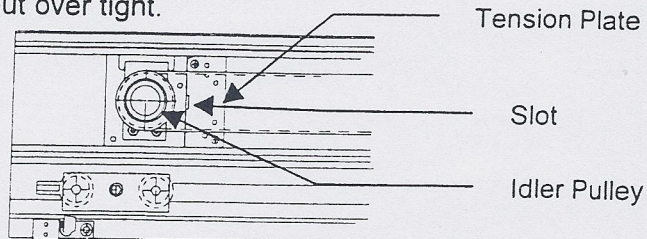

The electric lock system can be either "Fail Safe"(L2) or "Fail Secure"(L1). If the "Fail Safe" type is used, the lock will unlock when power is removed from the door. The "Fail Secure" lock (shown) remains locked when the power is removed.

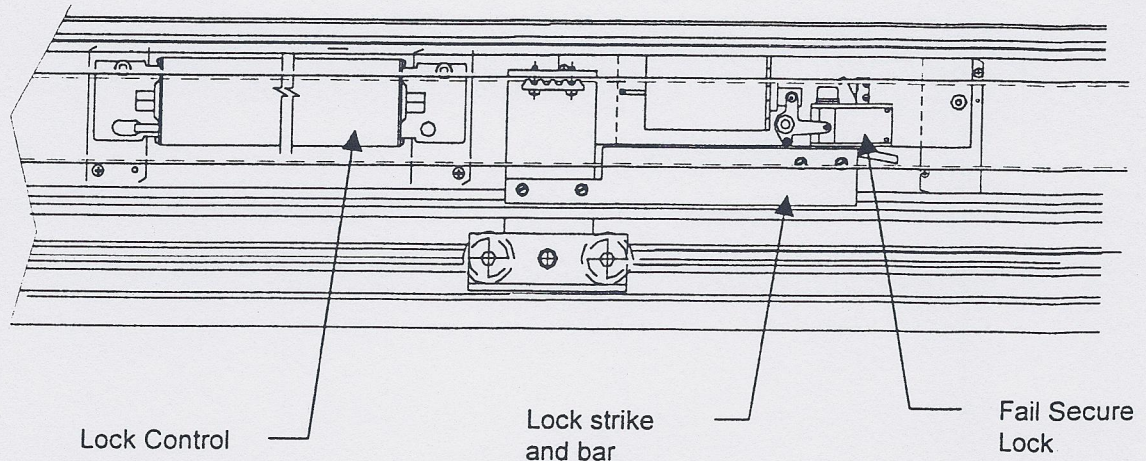

Typical Lock Connection

For applications where the lock has been installed after the fact, be sure to set the SZ-6 switch to the down or "YES" position, and all connections are as shown below.

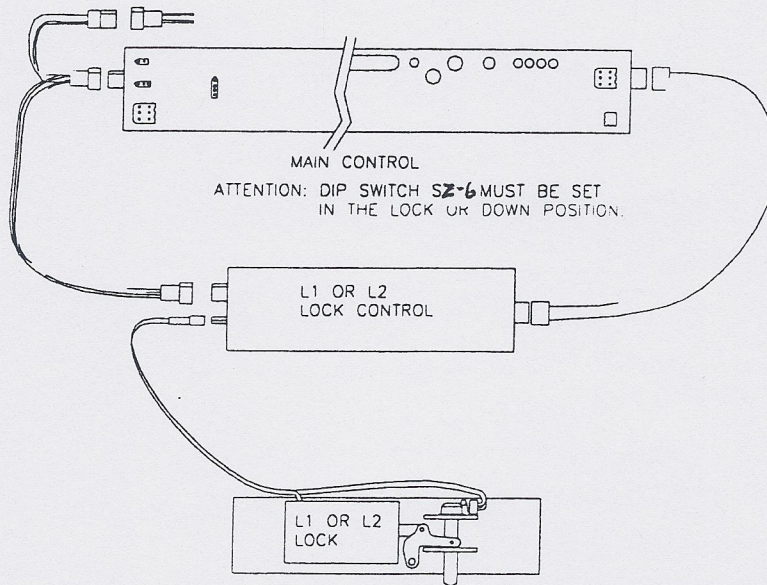

CONNECTED TO RED PLUG
DN CONTROL

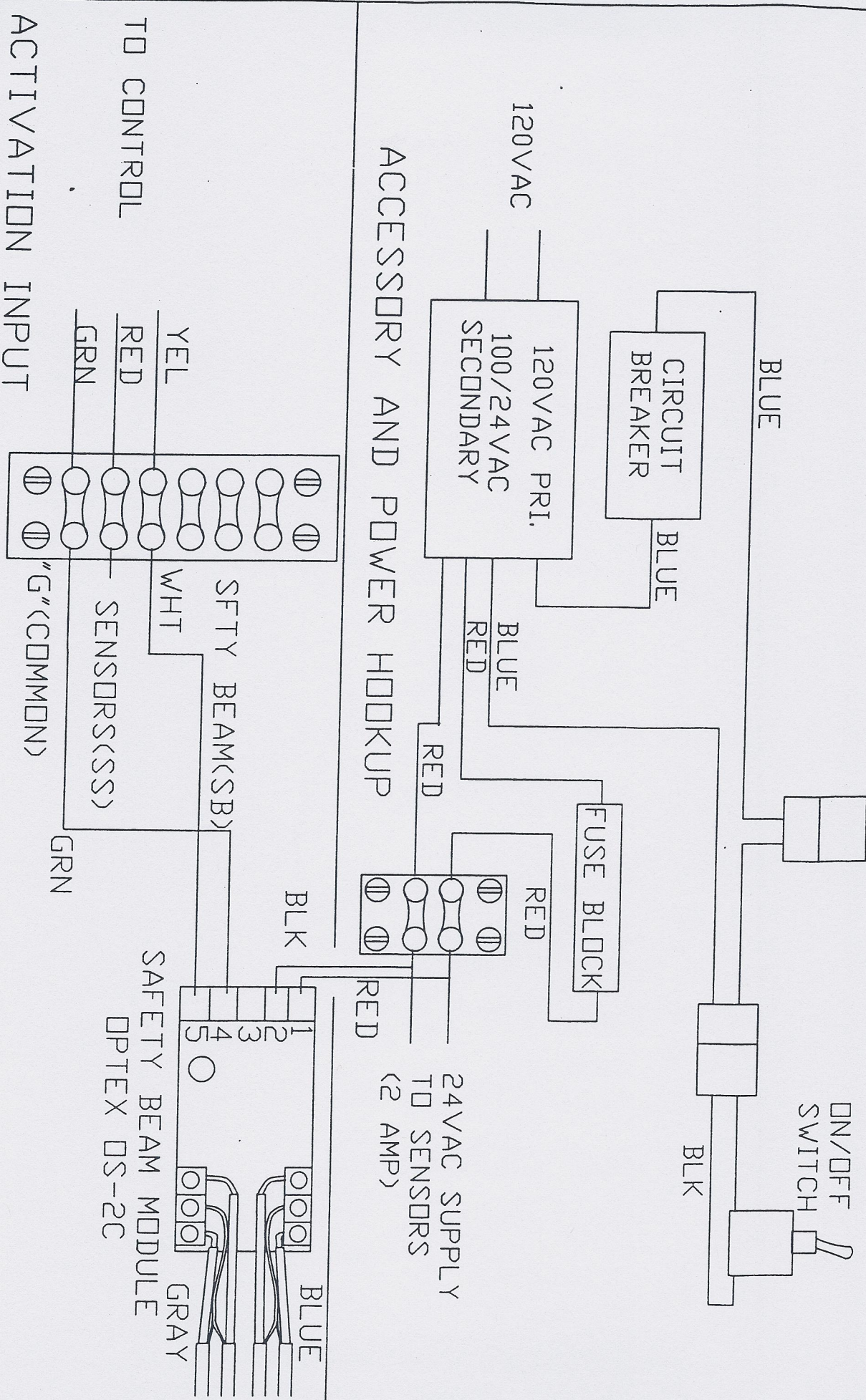

ACCESSORY AND POWER HOOKUP

ACTIVATION INPUT

TD CONTROL

TEMP. NO.

WD-1100-7

DATE: 5-5-97

DESCRIPTION:

SERIES 1100 ELECTRICAL HOOKUP
WITH OPTEX DS-2C BEAMS



AUTOMATED ENTRANCE SYSTEMS

K&M SYSTEMS, INC.

4910 STARCREST DRIVE (28110)
P.O. BOX 3098
MONROE, NC 28111-3099 U.S.A.