

DOR-O-MATIC

B U L L E T I N

T B 4

SUBJECT: DYNAMIC BRAKE HARNESS NOW REQUIRED FOR MID-SWING™

This past September, Dor-O-Matic updated its Astro, Senior and Mid-Swing operators to make them fully compliant with new U.L. requirements. These control boxes have fuses built into the harness.

Dor-O-Matic is now supplying updated Mid-Swing operators, 83803-901/902 by providing a dynamic brake circuit. In the event of a blown fuse, this circuit will assure a more uniform speed and prevent door slamming on Mid-Swing units used with the new U.L. upgraded control box.

**ALL NEW MID-SWING OPERATORS WILL SHIP WITH
THE DYNAMIC BRAKE CIRCUIT INSTALLED**

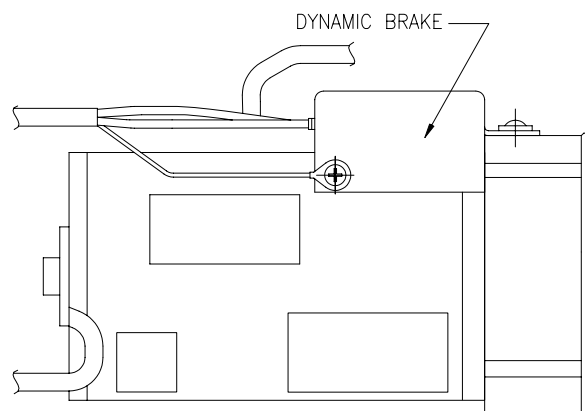

#83803-901/902 new style motor gear box for Mid-Swing

In addition, with all shipments after October 30, you will receive two dynamic brake harnesses packed with each replacement #85455-900R/400R Mid-Swing control box at no additional cost.

IF YOU HAVE A MID-SWING MOTOR GEARBOX (PART NUMBER 83800-901/902 ONLY) INSTALLED IN THE FIELD, AND UPGRADE THE CONTROL BOX, IT IS MANDATORY TO ADD THIS DYNAMIC BRAKE HARNESS.

The dynamic brake harness is a simple cable with two plugs. It attaches easily to the operator. It is simple to install, and your customers will appreciate having the very latest product upgrade to ensure complete safety on their Mid-Swing installation.

SAFETY REMINDER: In all older installations, the door will slam when the control box is disconnected from the motor so be careful when servicing doors.