

**KEANE MONROE**

*a member of the record group*

MONROE, NC, USA 28111

800 438 1937



**SERIES 3000 / 3100**

**INSTALLATION INSTRUCTIONS  
MICROPROCESSOR CONTROL**

**REGULAR ARM**

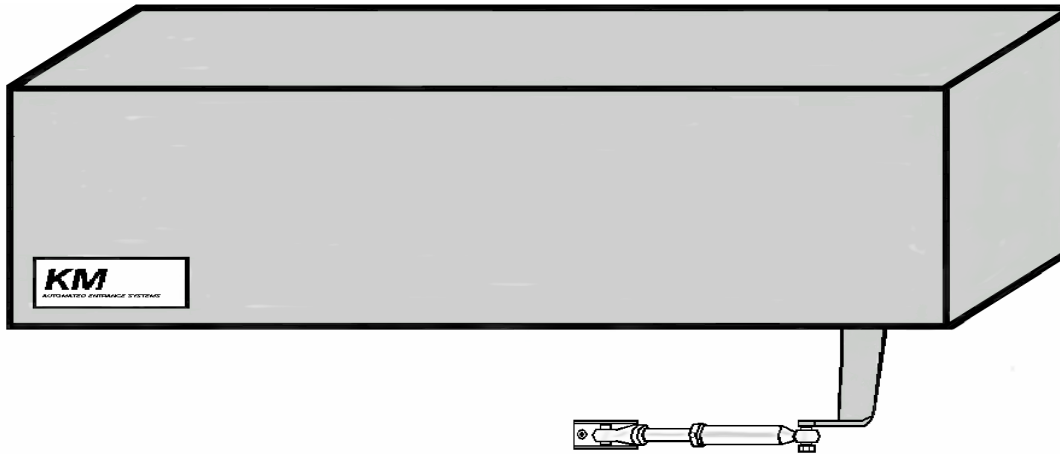

---

**SLIDE ARM / SLIDE ARM W/PANIC BREAKAWAY**





The KM Series 3000/3100 operators have been carefully designed, built, and tested to provide years of service.

The life of these operator packages is directly related to how carefully the installation is accomplished and how accurately the instructions are followed. Installation of these operator packages should be done by properly trained and knowledgeable installers with a knowledge of local code requirements and the requirements of ANSI A156.10 Standards for Power Operated Pedestrian Doors and ANSI A156.19 Standards for Low Energy and Power Assisted Pedestrian Doors. The authorized service/installation dealer must perform all measurements for forces, speeds, and times to insure proper and safe operation.

KM Systems is not responsible for improperly adjusted or maintained automatic doors or activation/safety systems and assumes no responsibility for damages caused by automatic door systems that have not been properly installed, tested, and adjusted.

**INDEX**

**HAND OF DOOR IDENTIFICATION..... 1**  
**ELECTRICAL PREPARATION..... 2,3**  
**HEADER PREPARATION AND INSTALLATION..... 4,5,6**  
**OPERATOR INSTALLATION- RH OUT & LH IN..... 7**  
**OPERATOR INSTALLATION- LH OUT & RH IN..... 8**  
**OPERATOR HANDING & TIMING..... 9**  
**CONTROL IDENTIFICATION, INSTALLATION, & SETUP..... 10,11**  
**REGULAR ARM INSTALLATION-BUTT HINGE..... 12**  
**REGULAR ARM INSTALLATION-CNTR. PIVOT..... 13**  
**SLIDE ARM INSTALLATION- BUTT HINGE & CNTR. PIVOT..... 14**  
**DOOR SPEED TABLES..... 15**  
**COVER INSTALLATION..... 16**  
**SIGNAGE AND CODE CONFORMANCE..... 17**  
**ADJUSTMENT AND WIRING DIAGRAM..... 18,19**

**READ INSTALLATION INSTRUCTIONS BEFORE INSTALLING.**

The sequence of installation and adjustment is in order, however some sections will not apply. Review this instruction manual and determine those sections that do apply. Be sure all doors swing freely and clear all objects before attaching arms.

Special attention needs to be given to installations with parallel and slide arms when an adjacent wall is perpendicular to the door frame.

**HAND OF DOOR IDENTIFICATION**

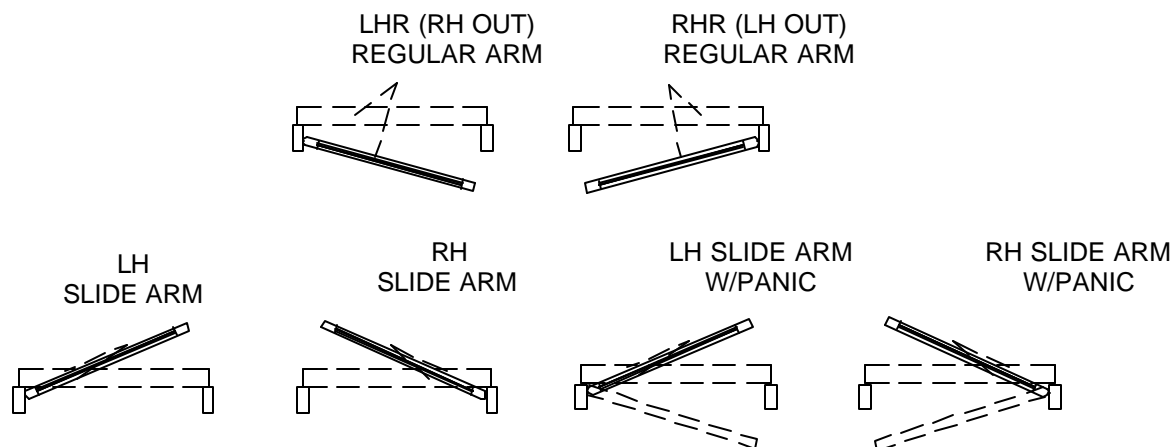



**OWNER INFORMATION TO BE PROVIDED BY THE DISTRIBUTOR / INSTALLER**

- After the installation, instruct the owner on the safe operation of the door.
- Location and proper use of the power switches.
- Location of the power breaker.
- Necessary warnings not covered in general instructions.
- Owners Manual and Daily Checklist.
- Phone number(s) for the local servicing dealers.
- What to do in the event a dangerous situation should occur, and how to shut the doors down and call for service.

**Electrical preparation**

**Before preparing jambs, determine the method and requirements for the electrical wiring involved and whether mats or other type of activation is used.**

For mounting on/off switch proceed to Operator Installation section.

**CAUTION:** Some local codes require on/off switches to be located no more than 6'6" above the floor. A suggested method of installation is to prepare a 1 1/2" dia. hole as shown. To install, place switch through top hole (1 1/2" dia.) while holding lead wires, lower switch to second hole (1/2" dia.) and fish out toggle end of switch. Install tabbed legend washer with mounting nut and secure with self tap screw.

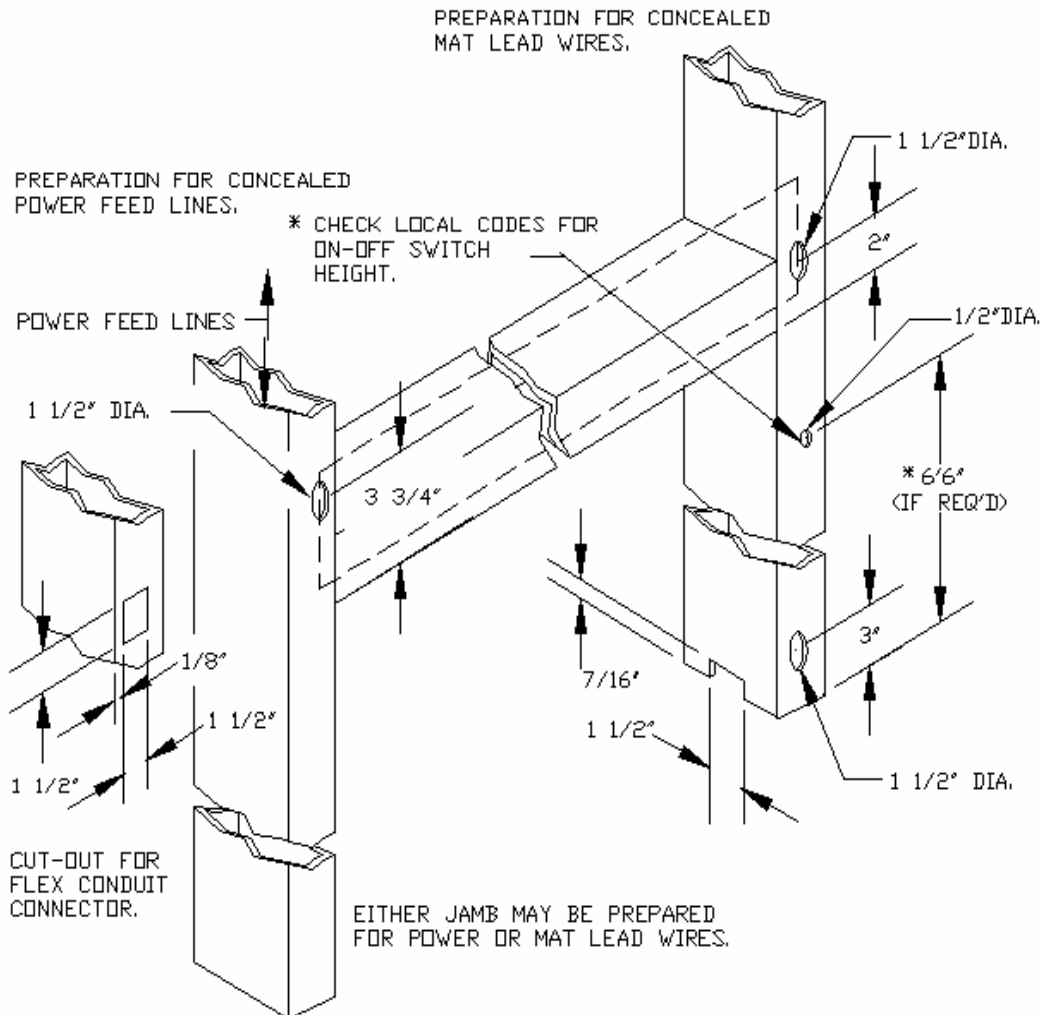



INSTALLATION INSTRUCTIONS  
ELECTRICAL PREPARATION

**Electrical Power**

**Concealed**

Run flexible conduit or 3-wire cable down side jamb, through cutout. Trim sufficient length of wire and insert into 90° connector. Attach connector to bracket and secure with locknut. Trim wire to proper length when wiring unit. Secure wire to operator base or control.

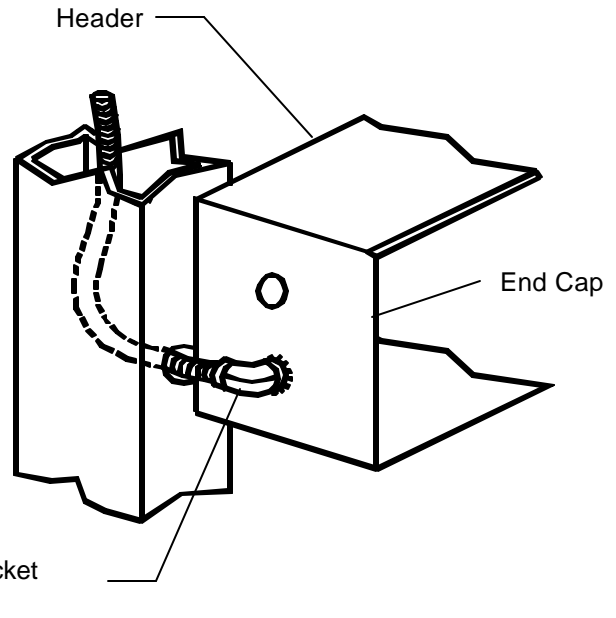

**Surface Mount**

Connect 90° elbow to bracket as shown, pull sufficient length of wire. Trim to proper length when wiring unit. Secure ground wire to base or control.

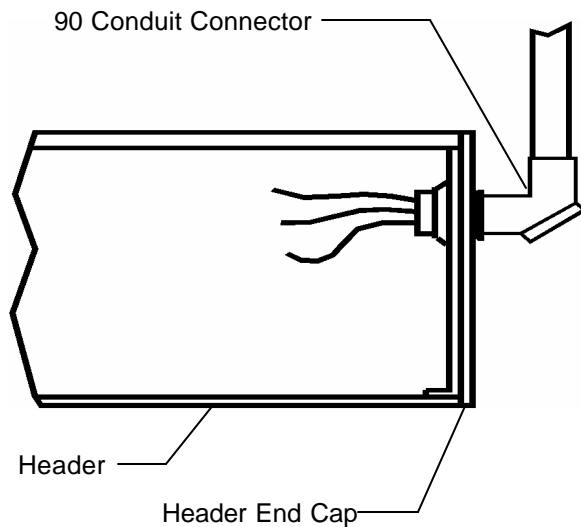



**Header Installation**

Before preparing the frame for the header, determine if the equipment is the correct hand and arm type. To properly identify the hand of the door, refer to the Hand of Door Section on page 1. The header shown below is a left hand out (RHR) or (RH) right hand in. (shown with hidden door stop for RH iN)

**Mounting the Header**

Be sure there is proper support in the wall to secure the header at the vertical jambs, and behind the header at intervals between the vertical jambs. Secure to top of door frame with the appropriate fasteners as indicated in "Hole Instructions" below.

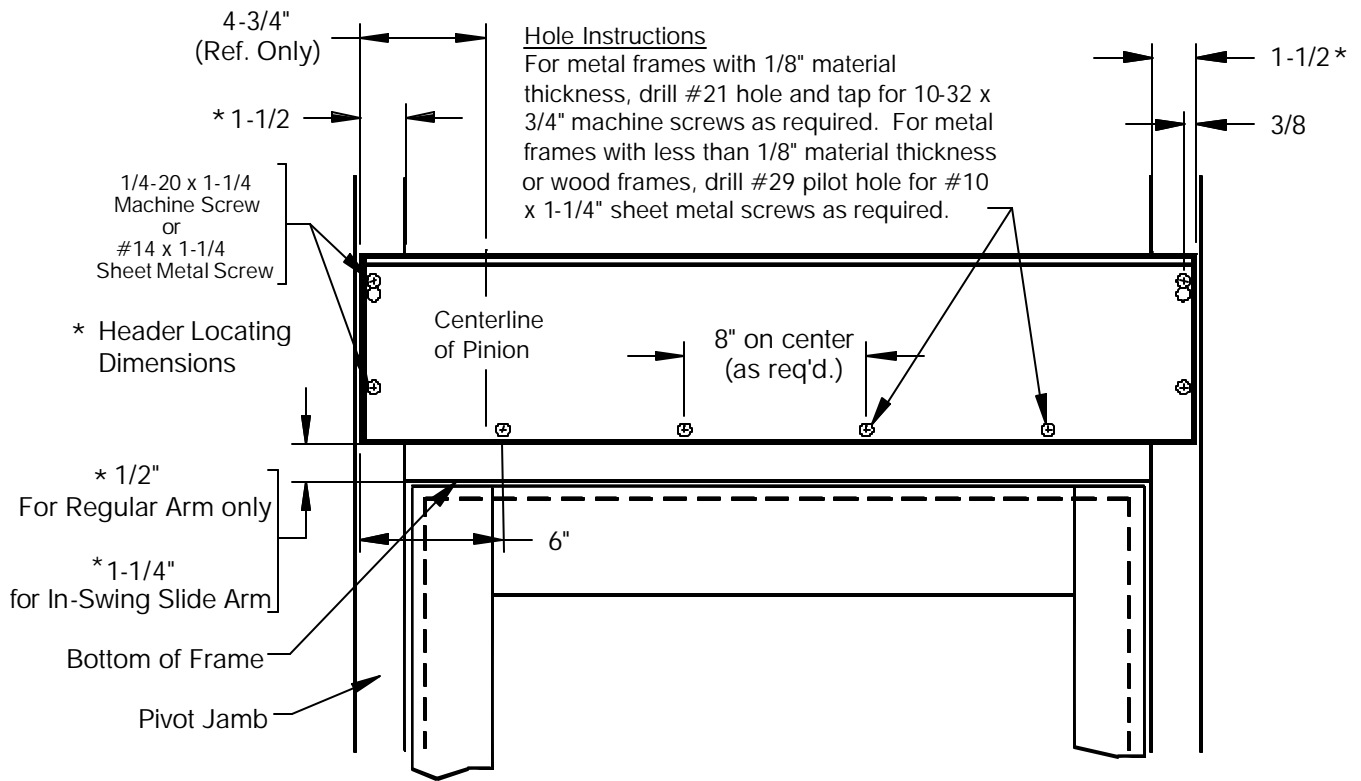

**Warning :** Do not permit the operator pinion to drop below the bottom of the door frame for inswing applications.

- Note:**
1. All door frames for regular and parallel arm operation must be provided with door stops.
  2. Door and frames for parallel operation with panic breakaway must be center pivoted or be capable of swinging in both directions with no stops.
  3. For exterior installations, mount the on/off switch on the bottom of the header, not on the endcap.



Header Anchorage

Aluminum Frame

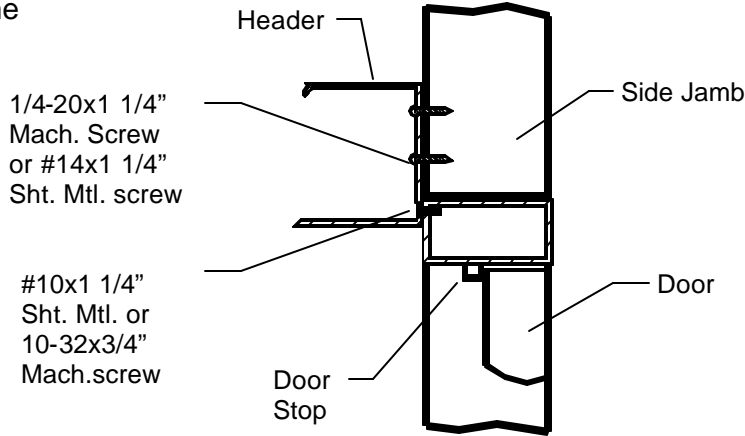

Hollow Metal Frame

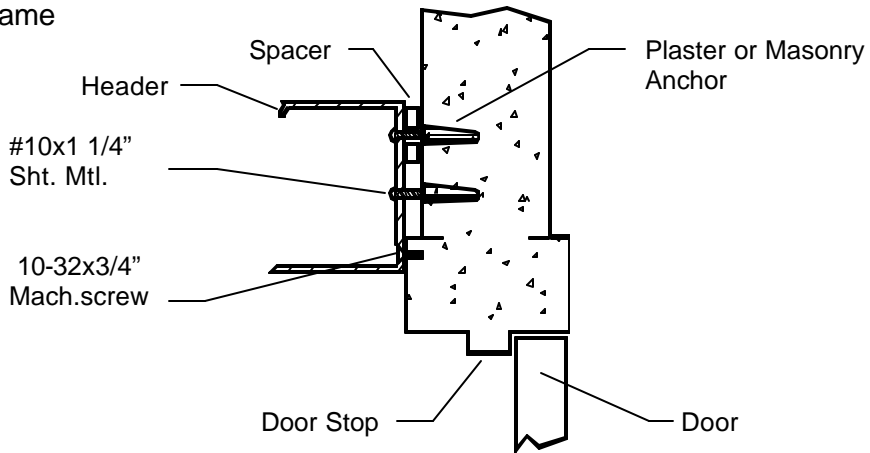

Wood Frame

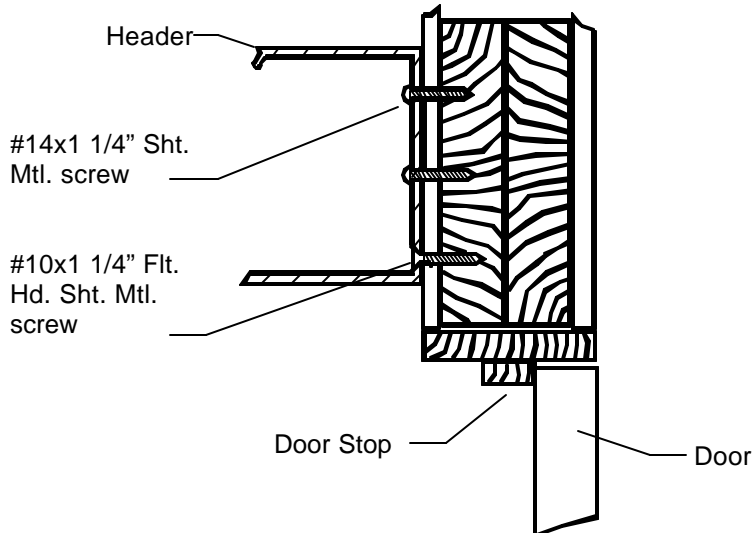



**Header Endcap Installation**

1. Install header endcap brackets to header with 10-32 flat head screws. ( For dual units, center bracket is required.)
2. Install endcap to each end bracket after removing perforated knockout where needed for conduit connection for electrical service.
3. Locate header on door frame as shown on page 4 and secure.

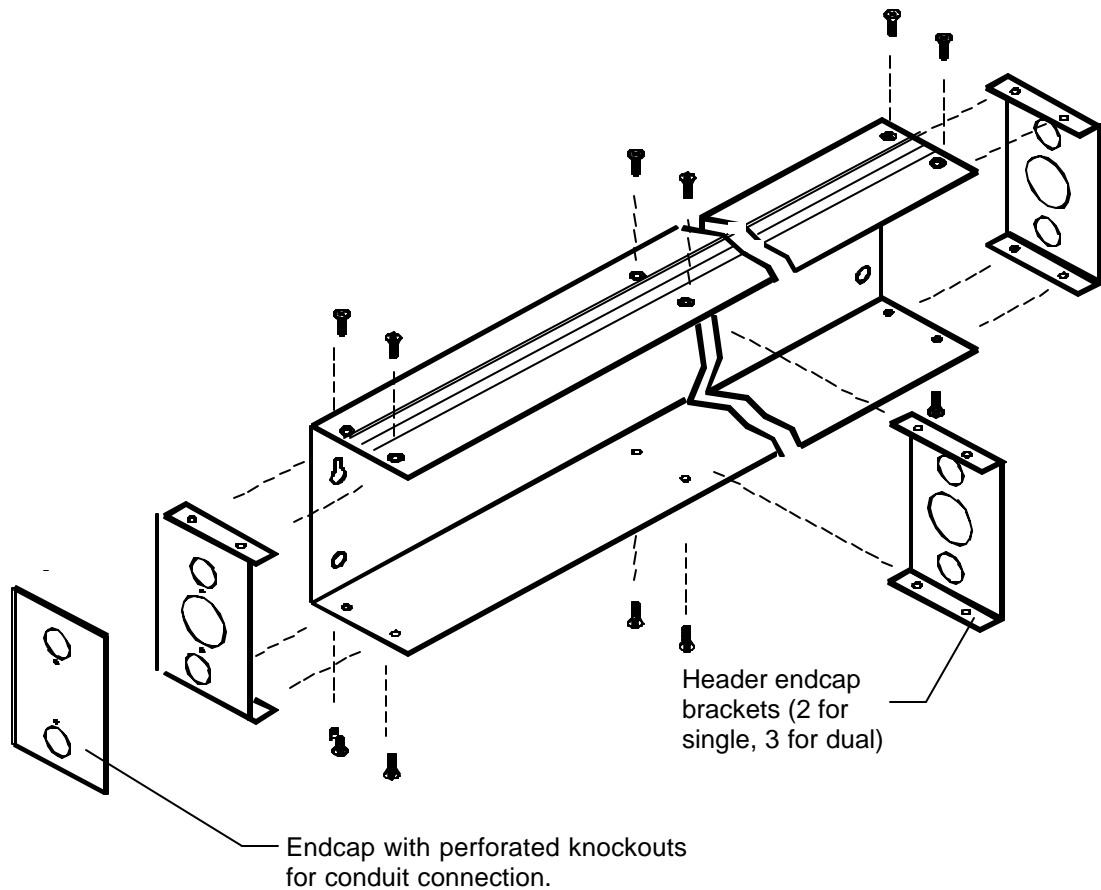

**Note:** If the header being installed is a small dual, it may be necessary to omit the center support bracket in order to install the control.



**OPERATOR MOUNTING - REGULAR & SLIDE ARM**

**READ PAGE 10 & 11 BEFORE CONNECTING CONTROL**

LHR (RH OUT) SHOWN & LH IN, RHR (LH OUT) & RH IN OPPOSITE.

Install the operator in the header as shown below; align the four mounting holes in the header with the shock mount grommets on the operator.

Use the 1/4-20 flat head screws provided to secure the operator through the header and shock mount grommets and into the pre-attached clamping plates inside the operator.

**READ PAGES 10 & 11 BEFORE PROCEEDING ANY FURTHER!!**

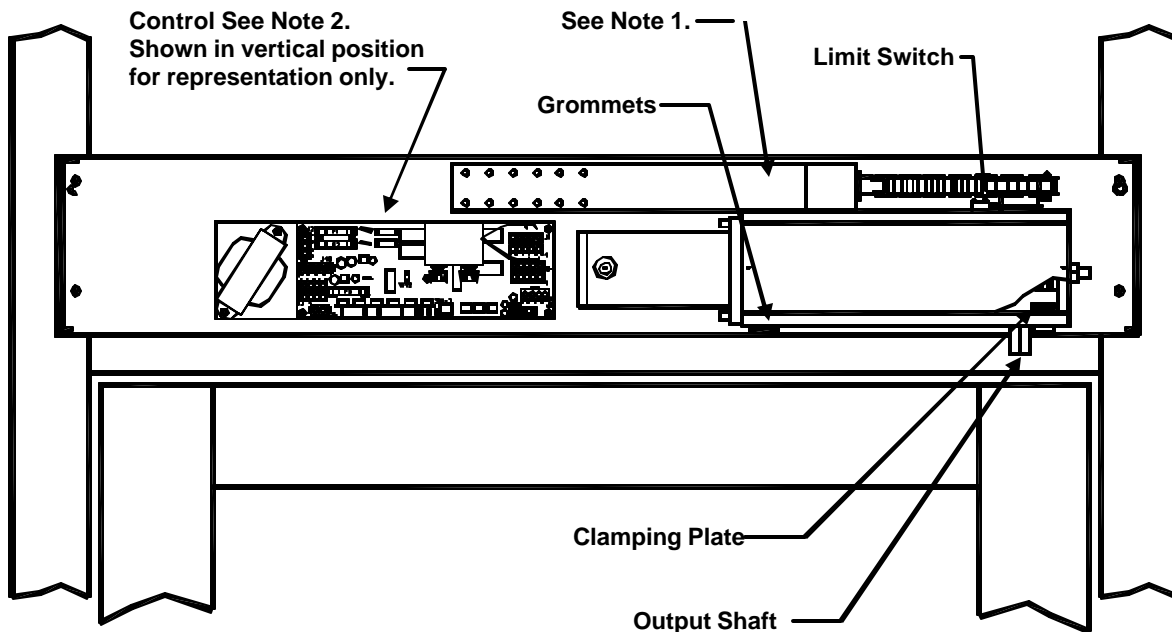

**Note 1.** For LH IN, the spring tube is towards the cover and the limit switch is opposite.

**Note 2.** Before installing the control see Pages 10 & 11 for setup instructions.

**Shaft Timing:**

The operator output shaft is in the full panic position when received from the factory.

See Pages 12 & 13 for proper setup of arm / operator timing.

**Limit Switch:**

Once the door arm is installed, make sure the limit switch is set to provide proper latch check position to obtain safe door operation. (For door open settings see Page 15.)





**OPERATOR MOUNTING - REGULAR & SLIDE ARM**

**READ PAGE 10 & 11 BEFORE CONNECTING CONTROL**

LHR (RH OUT) SHOWN & LH IN, RHR (LH OUT) & RH IN OPPOSITE.

Install the operator in the header as shown below; align the four mounting holes in the header with the shock mount grommets on the operator.

Use the 1/4-20 flat head screws provided to secure the operator through the header and shock mount grommets and into the pre-attached clamping plates inside the operator.

**READ PAGES 10 & 11 BEFORE PROCEEDING ANY FURTHER!!**

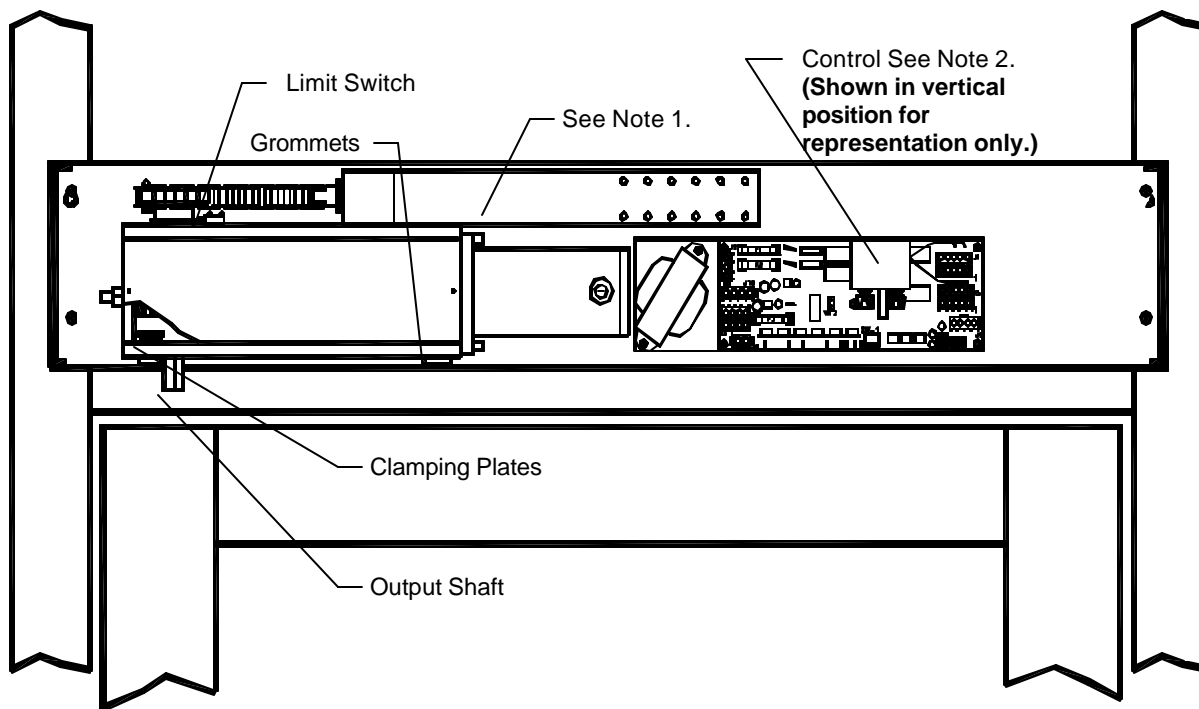

**Note 1.** For RH IN, the spring tube is towards the cover and the limit switch is opposite.

**Note 2.** Before installing the control see Pages 10 & 11 for setup instructions.

**Shaft Timing:**

The operator output shaft is in the full panic position when received from the factory. See Pages 12 & 13 for proper setup of arm / operator timing.

**Limit Switch:**

Once the door arm is installed, make sure the limit switch is set to provide proper latch check position to obtain safe door operation. (For door open settings see Page 15.)



INSTALLATION INSTRUCTIONS  
OPERATOR HANDING AND TIMING

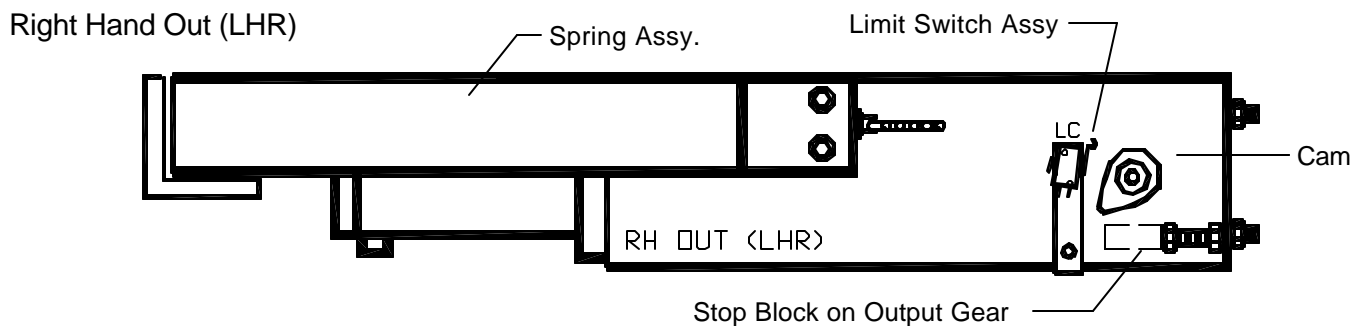
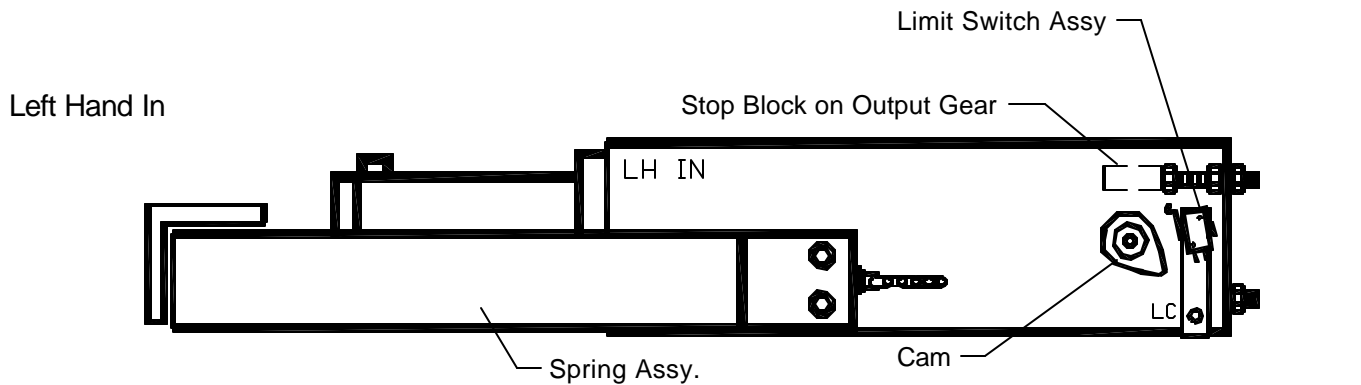
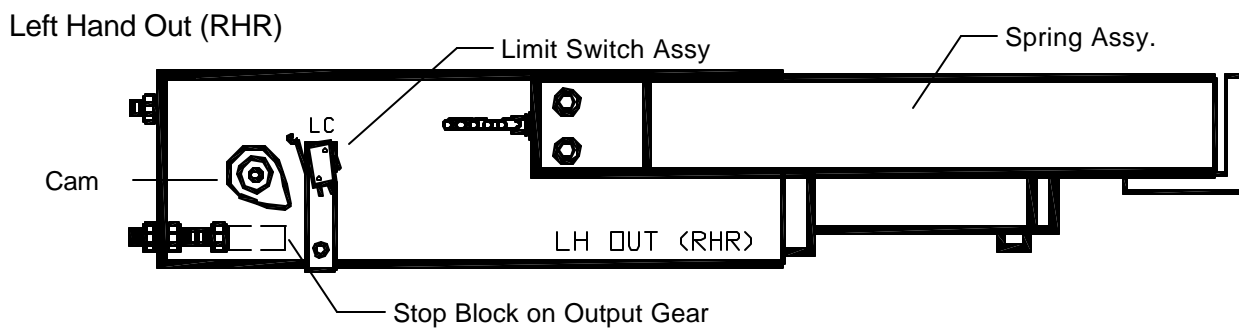
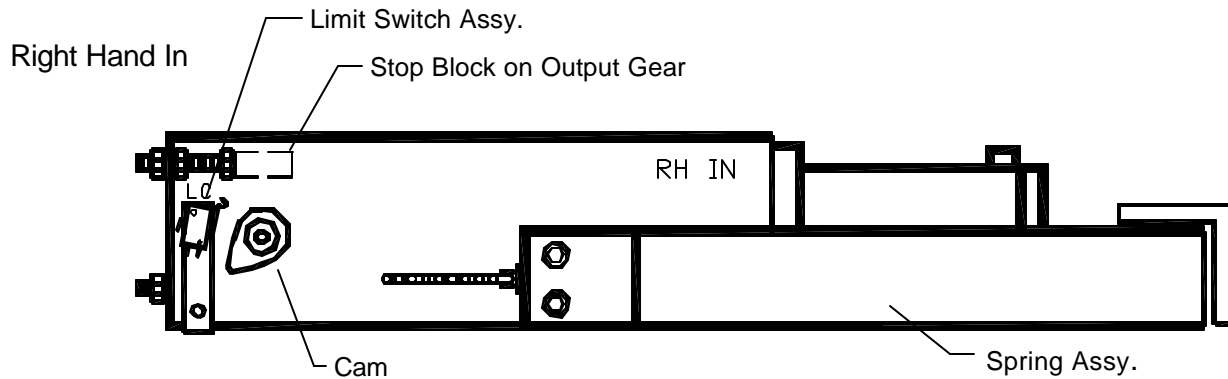

- Note: 1. The limit switch is labeled "LC" for latch check.  
 2. The stop block is located on the final stage gear and is shown in the door paniced position.  
 3. The door open and panic stop adjustment screws are shown, but the 90° door open position has to be calibrated as described on page 11.



The 3000 series control will be setup as either a **full power** (3000) control or a **low energy** (3100) control. To accomplish this the software is changed in the microprocessor. For ease of identification, the control will be marked with either an orange sticker or a green sticker located on the top of the close speed potentiometer bracket. The orange sticker is full power; the green sticker is low energy.

**FULL POWER CONTROL**

Orange sticker for full power  
Adjust to ANSI A156.10

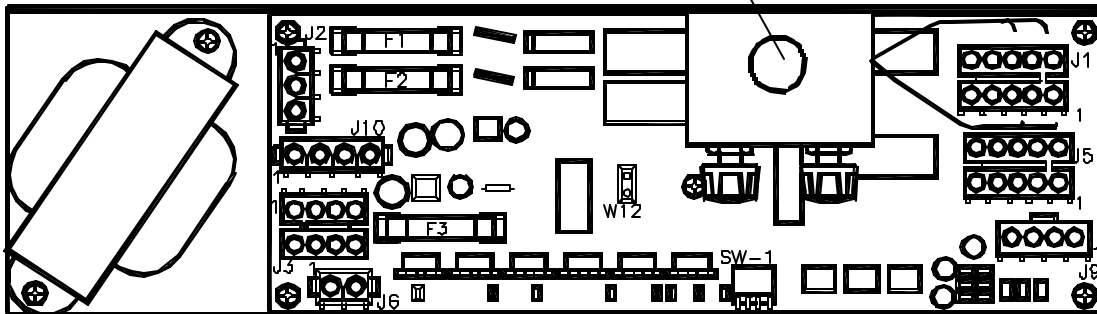

- The calibration jumper may not be in the jumpered position from the factory, see setup instructions for proper sequence of programming.
- The Obstruction Shut Down feature is recommended on full power applications. See adjustment diagram 8-30-0001 (pg 18) for location of adjustments.

**LOW ENERGY CONTROL**

Green sticker for low energy.  
Adjust to ANSI A156.19

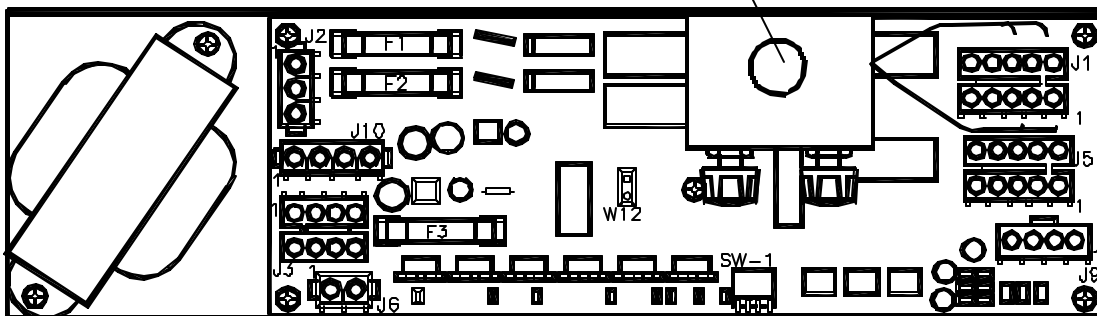

- The calibration jumper may not be in the jumpered position from the factory, see setup instructions for proper sequence of programming.
- The Obstruction Shut Down feature is recommended on low energy applications. See adjustment diagram 8-30-0002 (pg 18) for location of adjustments.

**INSTALLATION INSTRUCTIONS  
CONTROL INSTALLATION AND SETUP****Control Installation and Setup****DO NOT APPLY POWER TO THE CONTROL.**

**Completely clean the header area to make sure there are not metal particles on the circuit board or under the control that could cause a short circuit.**

**CAUTION: SHOCK HAZARD** Use caution when making any adjustments or connections to the control. As with all electrical controls, there are live voltages present on the board or components when the power is applied.

**Single**

Locate the control near the operator with the adjustment knobs positioned towards the cover. Connect operator, on/off/hold open harness, signal input harness, panic harness (if applicable), and power harness (**always connect last**) as shown on diagram 8-30-0003 at the back of this manual.

**Dual**

Locate control near the RH operator as described above. Use operator extension harness provided for the other operator and make all applicable connections as above.

**Setup Note:** Operators must be configured that when the door is at the 90° full open position, the stop block in the gearbox is to be against the stop bolt to achieve a good calibration.. Also, go to each operator harness plug, to the brown and yellow wire locations (encoder wires), and push in on them individually to make sure they are in and making contact.

**Suggested settings for Calibration:** Turn all the adjustment settings to the 12 o'clock position with the exception of Back Check speed; turn it all the way clockwise, and turn Time Delay to the 3 o'clock position.

To setup the control for programming, the calibration jumper (W12) must be in place (both pins) when power is applied. Once the door(s) is in motion, remove jumper and place it on one post for storage. The door(s) will go open slowly to the full open position (against the stop block in the gearbox) and drift back slightly, stop and then close. During this process, you will observe LED's alternately blinking. An operator plugged into the J1 connection on a single or dual control will have the red "OBS" LED and the yellow "PTS" LED blinking as the control receives information from the encoder/motor. In the case of a dual control, with the second operator plugged into the J5 connection, you should also observe the green "SYS" LED AND THE RED "APU" LED blinking as it also receives encoder information. One or both appropriate LED's not lighting (blinking) during calibrate indicates lack of encoder information from that operator.

Once this sequence has occurred, the control is ready for normal operation. Recalibrate if the door is not allowed to get to the door open position (to the hard stop).

**Attention: When the power switch is turned on in the morning, the door must go completely to the door open position (against stop block in gear box) in order to run properly. Should the door meet an obstruction, turn the door off, remove obstruction, and reapply power.**

Once the operator has gone through the calibration process, adjust the door speeds and check positions according to the type of installation (full power or low energy). The control can provide several features for different types of applications; See page 9 for ANSI adjustment and the control diagram in the back of this manual for adjustments. **Caution! When adjusting door open speed, obstruction sensitivity must be adjusted accordingly. (e.g.— speeding the door up requires the Obstruction shutdown to be less sensitive).**

The four(4) position dip switch allows "Push-to-start", "Latch Assist", "Ratchet", and "Stack Pressure" to be selected by putting the switch lever in the down position.

**Accessory 24vac power (connector J6) is controlled by fuse F3 and is limited to 1 amp total. Use UL listed cable type CL2, CL2P, CL2R, or CL2X or equal for accessory connection.**



INSTALLATION INSTRUCTIONS  
REGULAR ARM - BUTT HINGE INSTALLATION

**Note:** Some installations will not have enough room to install the arm on the output shaft with the operator in the panic position. If this condition exists, allow the operator to go through a calibrate cycle and then put the control in hold open. Attach the arm to the operator and door and shut off the switch. Reinstall calibration jumper and let the control calibrate. Remember to remove the jumper and place on one post after the door is in motion.

REGULAR ARM - BUTT-HINGE INSTALLATION



DOOR FRAME MUST HAVE DOOR STOP

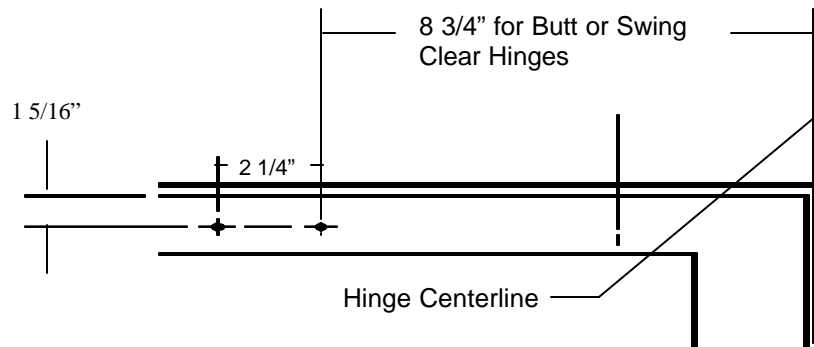

Hole Instructions

For **Metal Doors** with 1/8" surface thickness Drill #7 hole and tap for 1/4-20 x 5/8" M.S. (2 holes).  
For **Metal Doors** with less than 1/8" surface thickness or **Wood Doors**, Drill 3/16" pilot hole for #14 x 1 1/4" SMS (2 HOLES).

**Note:** All hole locations shown above are located from centerline of pivot or hinge.

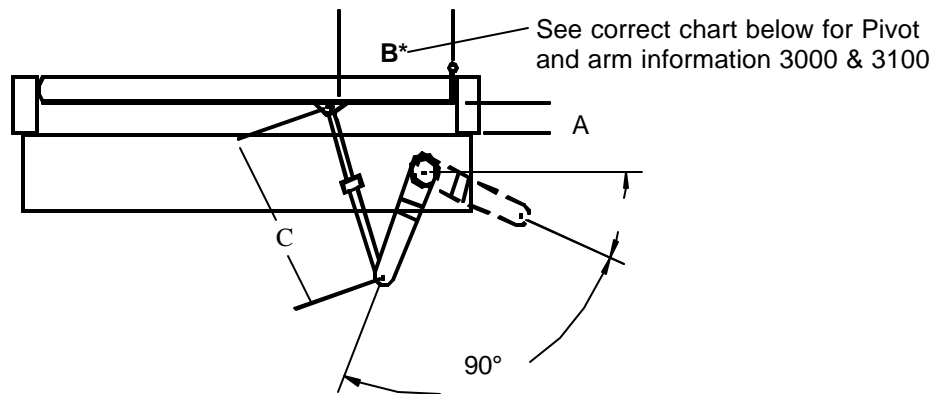

**Note:** "B" dimension is from center line of pivot location to first door shoe screw.  
"A" dimension is the depth of reveal from face of frame to face of door.

\* 3100

Depth of Reveal	A	2"	2 1/2"	3"	3 1/2"	4"	4 1/2"	5"	5 1/2"	6"
Pivot to 1st Dr Shoe Screw	B	8 3/4"	8 3/4"	8 3/4"	8 3/4"	8 3/4"	8 3/4"	8 3/4"	8 3/4"	8 3/4"
Total Sec. Arm Length	C	15"	15 1/2"	16"	16 1/2"	17"	17 1/2"	18 "	18 1/2"	19 "
Secondary Rod Length	--	13"	13 1/2"	14"	14 1/2"	15"	15 1/2"	16 "	16 1/2"	17"

\* 3000

Depth of Reveal	A	2"	2 1/2"	3"	3 1/2"	4"	4 1/2"	5"	5 1/2"	6"
Pivot to 1st Dr Shoe Screw	B	10 3/4"	10 3/4"	10 3/4"	10 3/4"	10 3/4"	10 3/4"	10 3/4"	10 3/4"	10 3/4"
Total Sec. Arm Length	C	16"	16 1/2"	17"	17 1/2"	18"	18 1/2"	19 "	19 1/2"	20 "
Secondary Rod Length	--	14 "	14 1/2"	15"	15 1/2"	16"	16 1/2"	17 "	17 1/2"	18"



**REGULAR ARM - CENTER PIVOT INSTALLATION**



**DOOR FRAME MUST HAVE DOOR STOP**

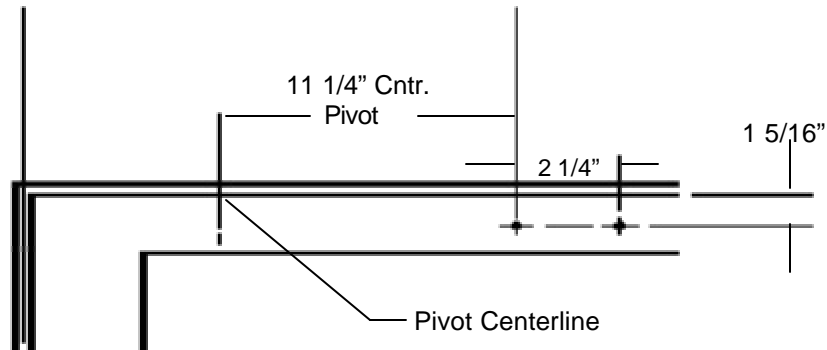

**Hole Instructions**

For **Metal Doors** with 1/8" surface thickness Drill #7 hole and tap for 1/4-20 x 5/8" M.S. (2 holes).  
For **Metal Doors** with less than 1/8" surface thickness or **Wood Doors**, Drill 3/16" pilot hole for #14 x 1 1/4" SMS (2 HOLES).

**Note:** All hole locations shown above are located from centerline of pivot or hinge.

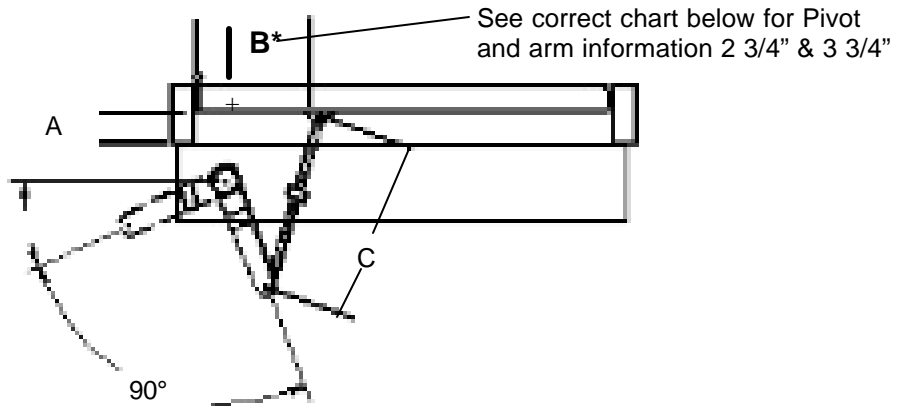

**Note:** "B" dimension is from center line of pivot location to first door shoe screw.  
"A" dimension is the depth of reveal from face of frame to face of door.

**\*2 3/4" Center Pivot**

Depth of Reveal	<b>A</b>	1 1/2"	2"	2 1/2"	3"	3 1/2"	4"	4 1/2"	5"	5 1/2"	6"
Pivot to 1st Dr Shoe Screw	<b>B</b>	11 1/8"	11 1/8"	11 1/8"	11 1/8"	11 1/8"	11 1/8"	11 1/8"	11 1/8"	11 1/8"	11 1/8"
Total Sec. Arm Length	<b>C</b>	15 1/2"	16"	16 1/2"	17"	17 1/2"	18"	18 1/2"	19"	19 1/2"	20"
Secondary Rod Length	--	13 1/2"	14"	14 1/2"	15"	15 1/2"	16"	16 1/2"	17"	17 1/2"	18"

**\* 3 3/4" Center Pivot**

Depth of Reveal	<b>A</b>	1 1/2"	2"	2 1/2"	3"	3 1/2"	4"	4 1/2"	5"	5 1/2"	6"
Pivot to 1st Dr Shoe Screw	<b>B</b>	11 1/8"	11 1/8"	11 1/8"	11 1/8"	11 1/8"	11 1/8"	11 1/8"	11 1/8"	11 1/8"	11 1/8"
Total Sec. Arm Length	<b>C</b>	16"	17"	17"	17"	17"	17 1/2"	18 1/2"	19"	19 1/2"	20"
Secondary Rod Length	--	14"	15"	15"	15"	15"	15 1/2"	16 1/2"	17"	17 1/2"	18"



SLIDE ARM - BUTT HINGE AND CENTER PIVOT  
RH SHOWN

BUTT HINGE

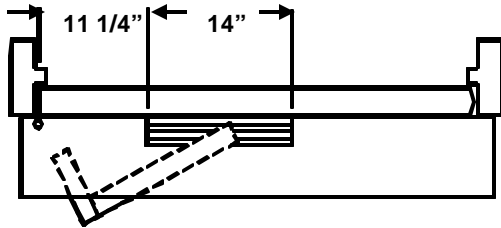

CENTER PIVOT (3 3/4")

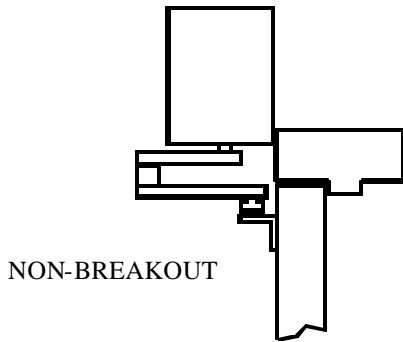
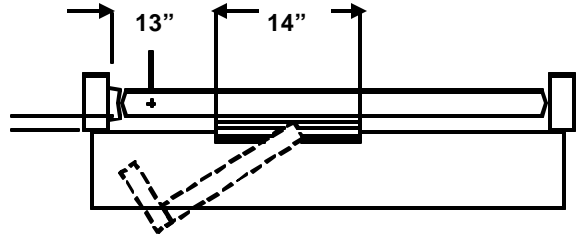

NON-BREAKOUT

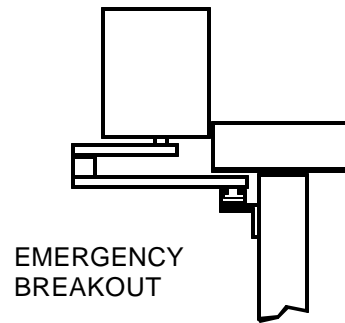

EMERGENCY  
BREAKOUT

DOOR PREP FOR SLIDE TRACK

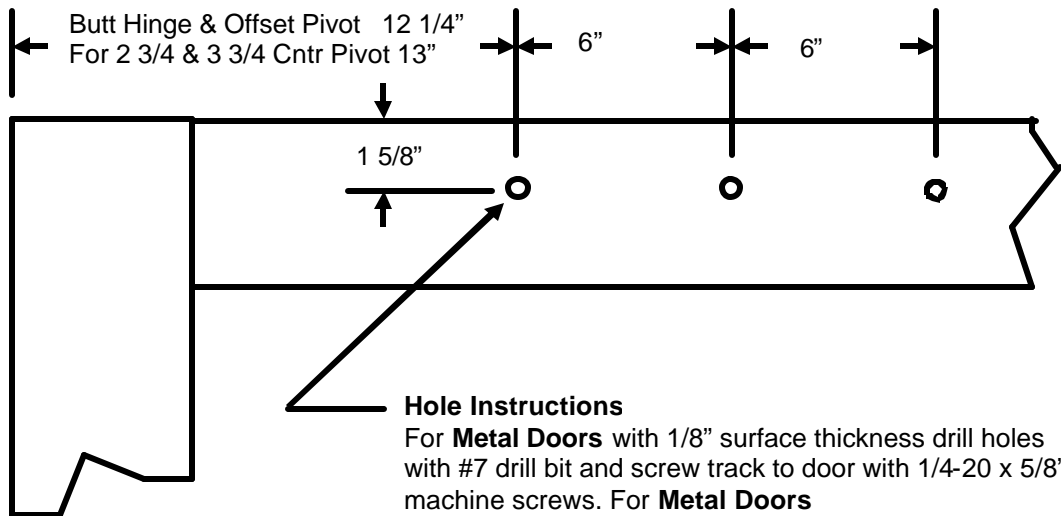

Hole Instructions

For **Metal Doors** with 1/8" surface thickness drill holes with #7 drill bit and screw track to door with 1/4-20 x 5/8" machine screws. For **Metal Doors** with less than 1/8" surface thickness or **Wood Doors** drill 3/16" pilot hole for # 14 x 1- 1/4" sheet metal screw.



**INSTALLATION INSTRUCTIONS  
DOOR SPEED TABLES**

**Full Power  
Door opening time**

The door opening time to back check for a full power installation shall not be less than 1.5 sec.

**Door closing time**

Refer to the table below for size, weight, and times.

**Important**

Test all functions of the operator using operational switching devices such as press wall switches, sensors, or mats and the on/off switch.

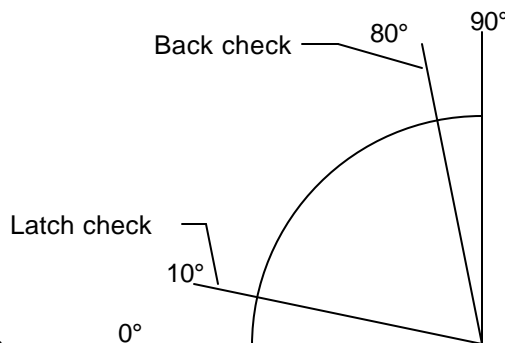

$$T = \frac{D \cdot W}{188 \text{ lb-ft}}$$

where T=Time  
D=Door Width  
W=Door Weight

**Timing of door close**

Door closing time from 90° to latch check

"D" Door leaf width Inches (mm)	"W" Door Weight in Pounds (kg)					
	100 (45)	101 (46) 140 (64)	110 (50.0)	111 (50) 150 (68)	120 (54)	121 (55) 160 (73)
36 (914) & Under	2.0 sec.					
36 (914)		2.3 sec.				
42 (1067)			2.3 sec.			
42 (1067)				2.7 sec.		
48 (1219)					2.8 sec.	
48 (1219)						3.2 sec.

**Low Energy  
Important**

Test all functions of the operator using operational switching devices such as press wall switches, sensors, or mats and the on/off switch.

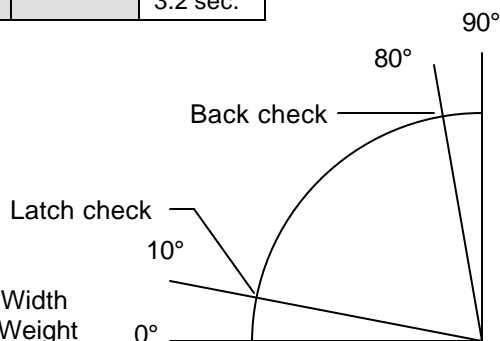

$$T = \frac{D \cdot W}{133 \text{ lb-ft}}$$

where T=Time  
D=Door Width  
W=Door Weight

**Timing of Door Swing**

Minimum opening times to back check or 80° or minimum closing times from 90° to latch check or 10°

"D" Door Leaf Width Inches (mm)	"W" Door Weight in Pounds (kg)				
	100 (45.4)	125 (56.7)	150 (68.0)	175 (79.4)	200 (90.7)
30 (762)	3.0 sec.	3.0 sec.	3.0 sec.	3.0 sec.	3.5 sec.
36 (914)	3.0 sec.	3.5 sec.	3.5 sec.	4.0 sec.	4.0 sec.
42 (1067)	3.5 sec.	4.0 sec.	4.0 sec.	4.5 sec.	4.5 sec.
48 (1219)	4.0 sec.	4.5 sec.	4.5 sec.	5.0 sec.	5.5 sec.

**Attention: These tables have been provided as a convenience for general setup.  
For complete specifications refer to ANSI A156.10 or ANSI A156.19**





INSTALLATION INSTRUCTIONS  
COVER INSTALLATION

COVER INSTALLATION

Install the cover into the top groove and rotate down until it snaps into the bottom lip of the header.  
Secure the cover with the 6-32 flat head screws across the bottom edge of the header.  
**USE CAUTION USING A DRILL / DRIVER TO INSTALL THESE SCREWS, THEY MAY STRIP.**

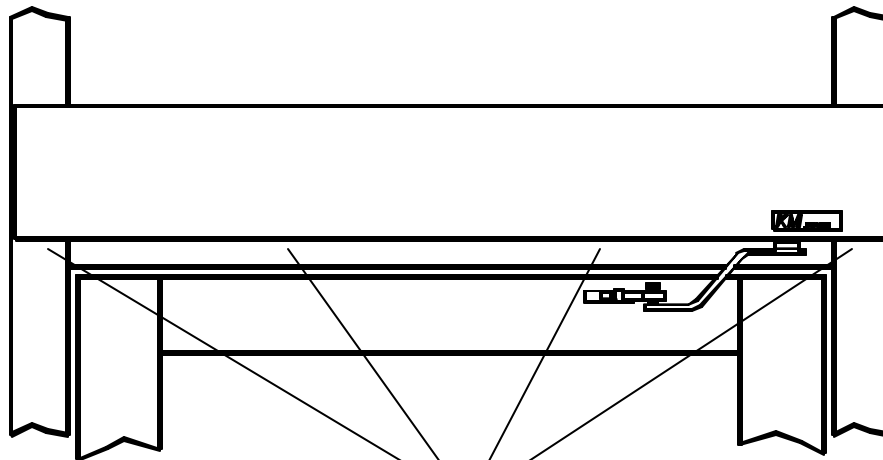
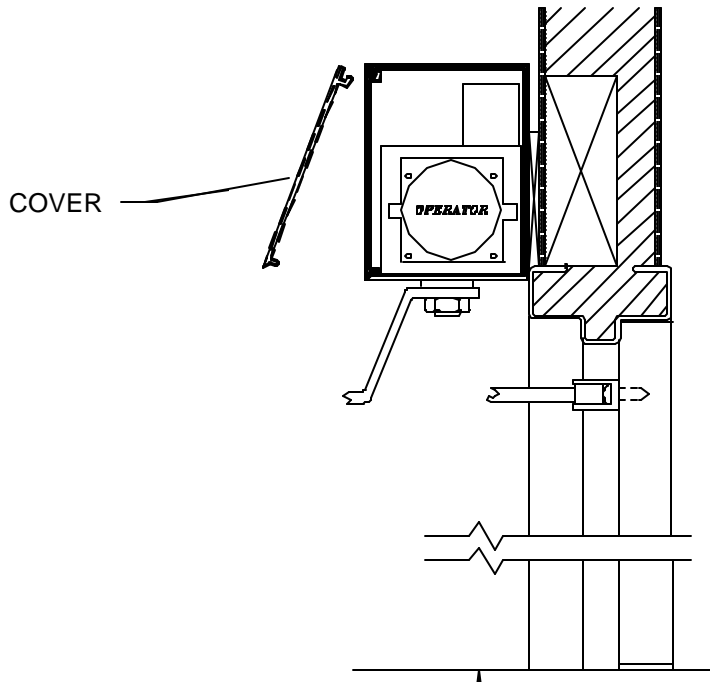

Install 6-32 screws here.  
Number of screw may vary.



**Signage Application**



Fig. 1

Make sure all doors have proper signage as follows. An arrow sign (Fig. 1) shall be visible from the approach side of a swinging door mounted on the door at a height 58 inches ± 5 inches (1475± 127mm) from the floor to the center line of the sign. The sign shall be a minimum of 6" (150mm) in diameter, having a green circle surrounding a black arrow on a white background.



Fig. 2

An international " **DO NOT ENTER**" sign (Fig. 2) shall be visible from the side of the doors that would swing towards pedestrians attempting to travel in the wrong direction mounted on the door at a height 58 inches ± 5 inches (1475 ±125mm) from the floor to the center line of the sign. The sign shall be a minimum of 6" (150mm) in diameter, having a red circle with the wording "**DO NOT ENTER**" in red circle.

Swing doors serving both egress and ingress shall be marked with a decal, visible from the swing side of the door, with the words " **AUTOMATIC CAUTION DOOR**"(SEE Fig. 3). The sign shall be mounted on the door at a height 58 inches ± 5 inches (1475 ± 125mm) from the floor to the center line of the sign. The sign shall be a minimum of 6" (150mm) in diameter and with black lettering on a yellow background.



Fig. 3

Install all signage according to the information above and to ANSI/BHMA A156.10 or A156.19 standards. Make sure all appropriate signage is applied to the door. Adjust the door forces and speeds to the above mentioned standards that apply to the door being installed. (See Control adjustment diagram to at the back of this manual to accomplish this).

**Code Conformance**

- Glass and glazing must comply with ANSI Z97.1.
- All electrical wiring must conform to National Electrical Code.
- Proper fingerguard must be applied to the hinge stile of the door. (Ref. UL325, Para. 27.12)
- All "Knowing Act" activation devices must be installed within eyesight of door motion.
- All public swing door installations must comply with either ANSI/BHMA A156.10 or A156.19.



INSTALLATION INSTRUCTIONS  
CONTROL ADJUSTMENT DIAGRAM

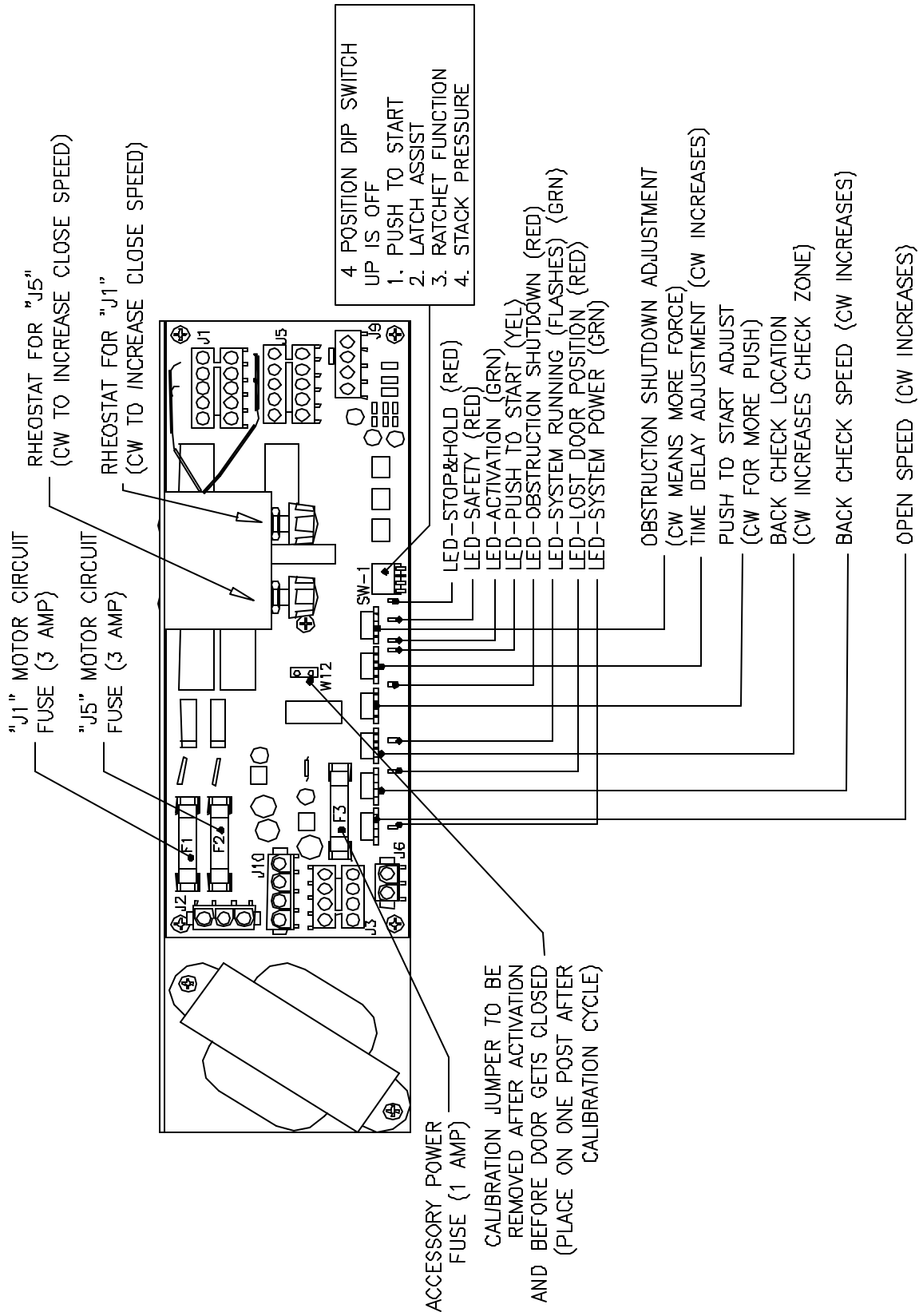

4 POSITION DIP SWITCH  
UP IS OFF  
1. PUSH TO START  
2. LATCH ASSIST  
3. RATCHET FUNCTION  
4. STACK PRESSURE

ACCESSORY POWER FUSE (1 AMP)  
CALIBRATION JUMPER TO BE REMOVED AFTER ACTIVATION AND BEFORE DOOR GETS CLOSED (PLACE ON ONE POST AFTER CALIBRATION CYCLE)

LED-STOP&HOLD (RED)  
LED-SAFETY (RED)  
LED-ACTIVATION (GRN)  
LED-PUSH TO START (YEL)  
LED-OBSTRUCTION SHUTDOWN (RED)  
LED-SYSTEM RUNNING (FLASHES) (GRN)  
LED-LOST DOOR POSITION (RED)  
LED-SYSTEM POWER (GRN)

OBSTRUCTION SHUTDOWN ADJUSTMENT  
(CW MEANS MORE FORCE)  
TIME DELAY ADJUSTMENT (CW INCREASES)  
PUSH TO START ADJUST  
(CW FOR MORE PUSH)  
BACK CHECK LOCATION  
(CW INCREASES CHECK ZONE)  
BACK CHECK SPEED (CW INCREASES)  
OPEN SPEED (CW INCREASES)

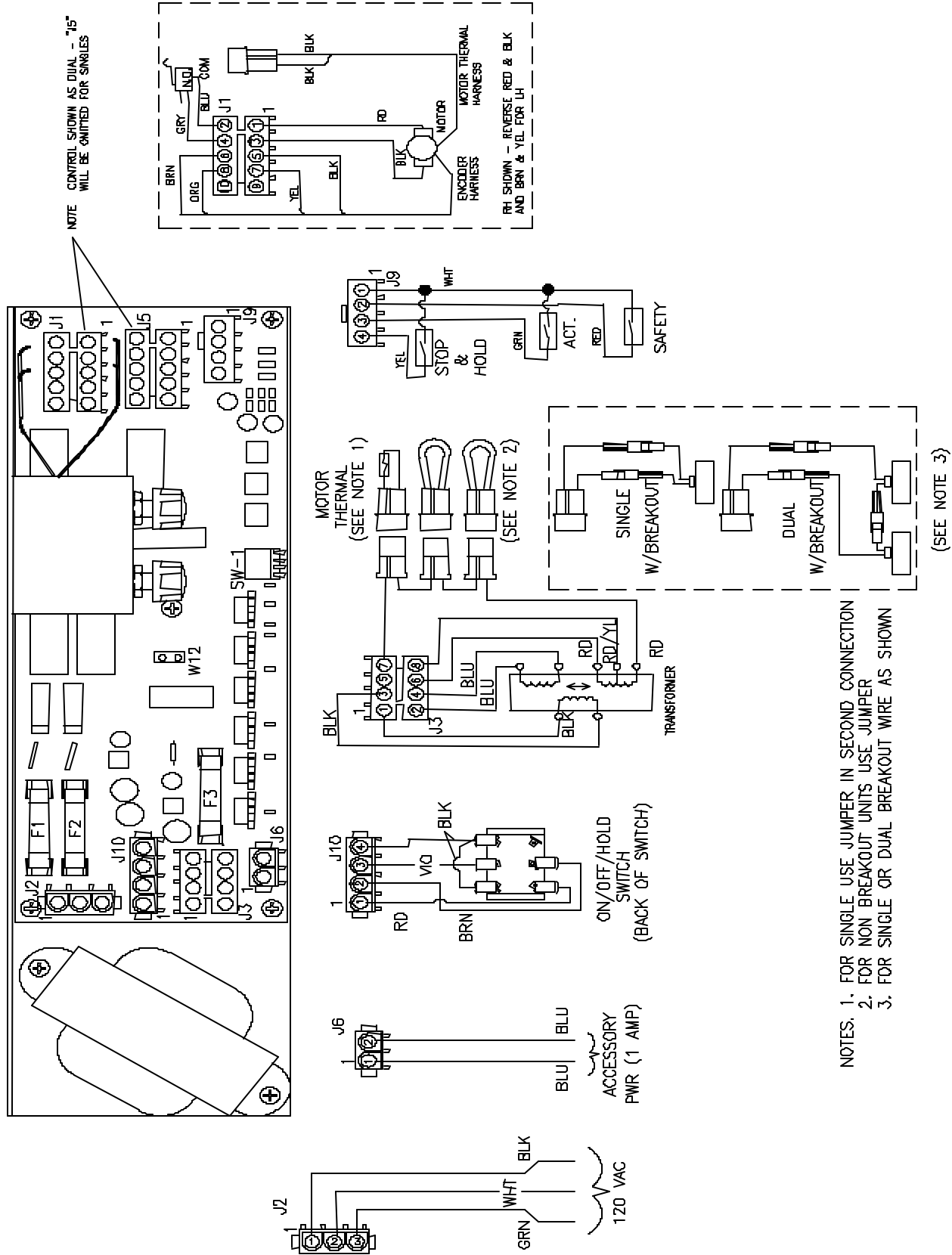

NOTES: 1. FOR SINGLE USE JUMPER IN SECOND CONNECTION  
 2. FOR NON BREAKOUT UNITS USE JUMPER  
 3. FOR SINGLE OR DUAL BREAKOUT WIRE AS SHOWN